

Flexible Vehicular Brick Paving

A Heavy Duty Applications Guide

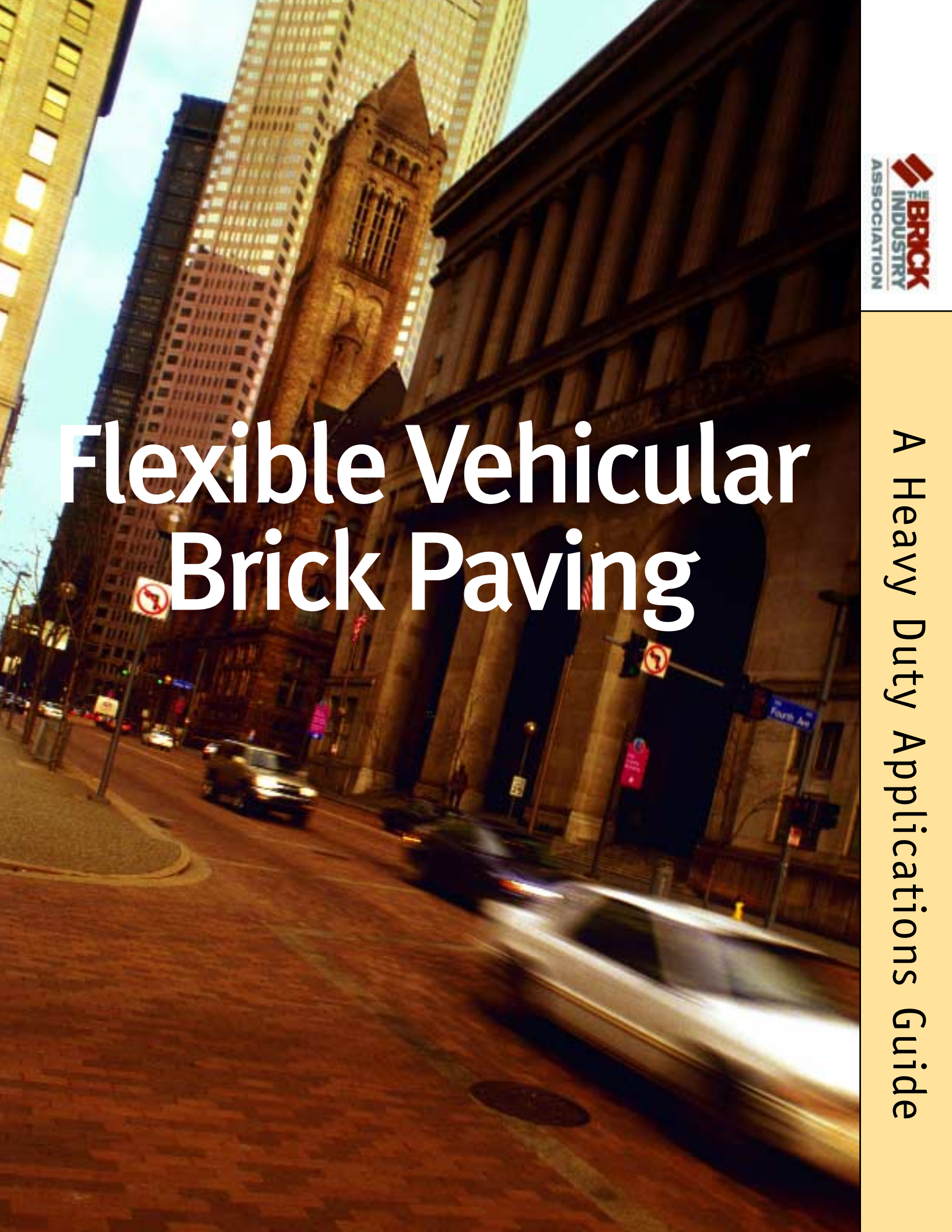

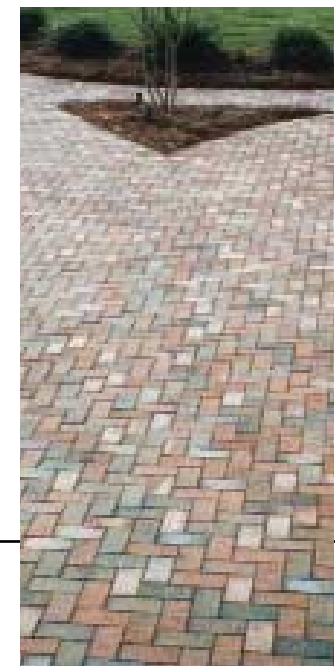
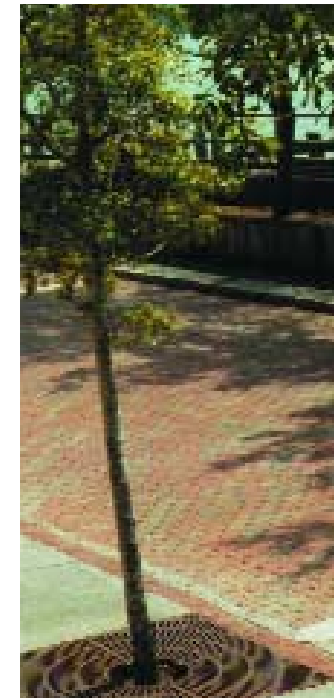
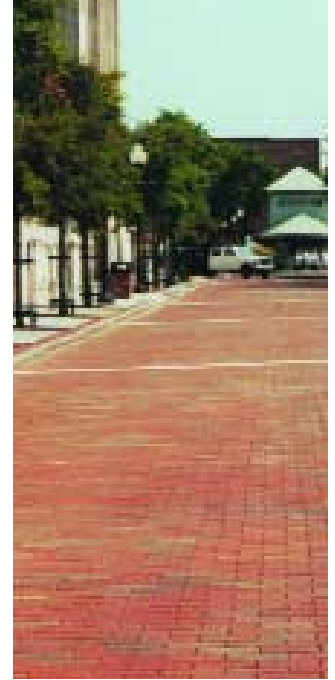

Contents

Foreword

This Guide was prepared by the staff of the Brick Industry Association (BIA) with the assistance of several members and a consultant. Instrumental in the development of the content were:

Brian Trimble, BIA, Reston, VA

Ted Corvey, Pine Hall Brick Company,
Winston-Salem, NC

Steve Jones, Pave Tech, Prior Lake, MN

Mark Smallridge, Mark Smallridge and
Associates, The Colony, TX

Mr. Smallridge is a paving consultant with considerable expertise and experience in segmental paving design and construction. His assistance was especially helpful. The members of the BIA Paving Committee also assisted in the review of this Guide.

Published and revised February 2004
Catalog Number: 530

Brick Industry Association
1850 Centennial Park Drive
Reston, VA 20191

Design Guide for Vehicular Brick Pavements	2
Introduction	2
General	4
Part I: Structural Design and Detailing	8
Introduction	8
Subgrade Classification	8
Traffic Analysis	12
AASHTO Design Concepts	13
AASHTO Design Solutions	14
CALTRANS Design Concepts	16
Design of Bituminous Setting Bed Systems	17
Mortared Brick Paving	17
Detailing	17
Design Examples	21
Part II: Materials	22
Introduction	22
Base and Subbase Materials	22
Soil and Base Stabilization	23
Setting Beds	23
Jointing Sand	25
Brick Pavers	26
Other Materials	28
Part III: Construction	30
Introduction	30
Subgrade	30
Subbase	31
Base	31
Sand Setting Bed	32
Bituminous Setting Bed	33
Paver Installation	34
Tolerances	37
In Service Considerations	38
Closing	39
References	40
Appendix A: Definitions of Terms	40
Appendix B: Referenced Standards	41
Appendix C: Guide Specification	42

Design Guide for Vehic

Introduction

The concept of segmental pavements (including clay bricks, concrete pavers, stone cobbles, stone and timber sets) is not new. Surviving segmental pavements can be traced back to the Romans and their network of roads, and to even earlier times. The oldest references to brick surfaced streets are believed to date back to Mesopotamian times, 5,000 years ago. Brick roads and streets provide a stable riding surface that is very durable. Brick has been used as a road paving material in this country since the late 1800's and was used through the early 1900's when the first national network of roads was constructed. Although the use of brick as a road surfacing material decreased with increasing vehicle speeds, and the improvement of concrete and asphaltic paving materials and construction methods in the 1930's and 1940's, it is still in use today. The rebirth of central business districts and new festival marketplaces demands that street and pedestrian areas be made of materials with a more human scale. The appearance, strength, warmth, and flexibility of brick meet this challenge.

Present day practices enable bricks to be set using three basic methods when they are constructed as a pavement surfacing material. These are the sand set, bituminous set and mortar set methods. The former two methods are flexible in nature and are covered in this publication. They are able to accommodate surface applied loads and environmentally induced stresses without the need for discontinuities such as movement joints. Mortar set brick surfaces are considered to be rigid, and require regular placement of movement joints. They are covered in other publications, including BIA *Technical Notes on Brick Construction* 14 Series.

Pavement design methods consider two different types of pavement. These are "flexible" pavements and "rigid" pavements. Flexible pavements spread the surface applied loads to the underlying layers by load distribution. The materials generally require lower strength properties with increasing depth, because the stresses reduce as the load is spread over a wider area. Rigid pavements spread the surface applied loads by flexure. Rigid pavements include a portland cement concrete slab and brick pavers set in mortar. A rigid pavement's thickness is frequently less than that of an equivalent flexible pavement.

Prior to the publication of the first edition of this Guide in 1993, the structural design of brick pavements had generally been based upon empirical methods. Their use had been primarily for pedestrian areas and streets subject to only light traffic. The Brick Industry

Association recognized the need for a rational approach to provide designers with the means of proportioning thicknesses of brick pavements for heavy vehicular applications such as major roads and streets. The American Association of State Highway and Transportation Officials (AASHTO) publication *Guide for Design of Pavement Structures* was revised in 1993 and provided a nationally accepted method that could be adapted to consider the flexible brick surface. Research on flexible pavements had demonstrated the equivalency of the brick and sand bed construction with other pavement materials considered in the AASHTO Design Guide. Therefore, it was only necessary to develop a suitable layer coefficient for the brick and sand bed in order to apply the AASHTO flexible pavement design methodology to the brick surfaced pavement.

ular Brick Pavements

Information in this Guide is based on research and development carried out around the world.

The previous version of this Guide provided instruction that was very comprehensive; however, many users expressed a need for a simplified method of designing flexible brick pavements. This version of the Guide provides such a method based upon specific applications and site conditions. The design solutions were prepared in accordance with the AASHTO method, and the input values are declared in the relevant sections of this Guide. There was also an identifi-

able need to include consideration of rigid pavement where portland cement concrete was mandated below the brick surfacing, as this was not covered in the previous version. In addition to these revisions related to the AASHTO design method, this edition also discusses an alternative design method for use in those states that have adopted the Caltrans design method or derivations thereof.

This Guide is intended to aid in the proper design, specification, and installation of brick paving systems. The designs present-

ed in this Guide are not intended as a replacement to the advice of an experienced pavement designer. Although the proposed pavement sections may be appropriate in developing preliminary sections and budget costs, it is recommended that an engineer with appropriate pavement experience certify the final design.



General

Flexible brick pavements, as defined in this Guide, consist of sand set or bituminous set brick pavers over layers of conventional pavement materials. The flexible brick pavement shown in Figure 1 consists of a compacted subgrade beneath a subbase layer, base layer, and setting bed surfaced with brick pavers and jointing sand. A subbase may not always be necessary between the subgrade and the base. An edge restraint is provided around the flexible brick pavement as part of the system. Sand set brick pavers, and to a lesser extent bituminous set brick pavers, with sand filled joints, develop interlock between adjacent pavers, which distributes the applied loads into the underlying layers. This does not occur with mortar set pavers. Mortared brick paving is only used over a concrete slab and is not covered in this Guide. Although this pavement type has been used successfully, the emphasis in this Guide is on flexible wearing surfaces. Information on other types of brick pavements can be found in *BIA Technical Notes on Brick Construction 14 Series*.

Interlock is a phenomenon that occurs in segmental pavements as a result of the interaction of the pavers and the jointing sand between the pavers. The tight, sand-filled joints transfer loads between

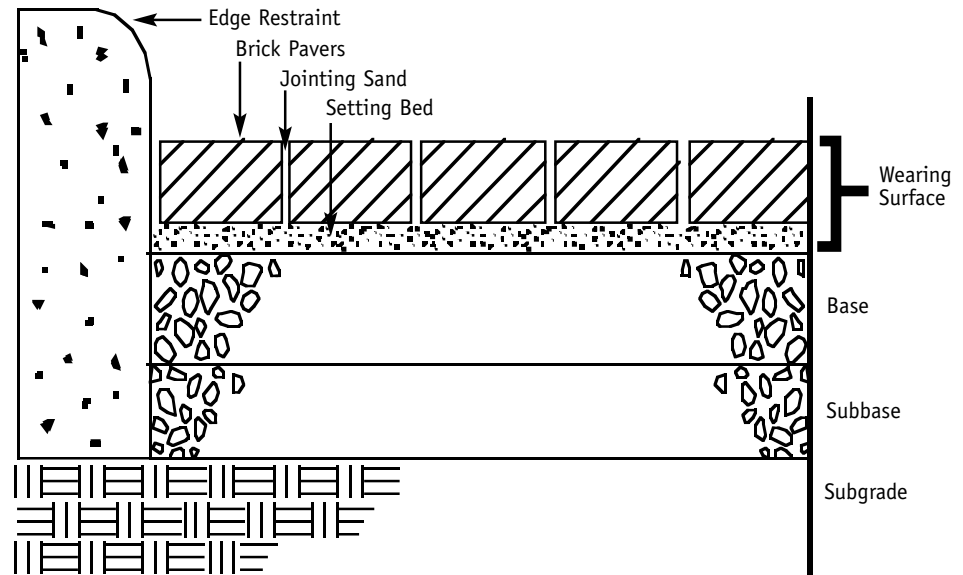

Figure 1: Flexible Brick Pavement

adjacent brick pavers through friction. Interlock increases over time as the joint sand becomes thoroughly compacted and debris builds up in the joints. When interlock is present, the wearing surface contributes to the strength of the system. Specially-shaped pavers provide little additional contribution to vertical interlock. However, some bond patterns, such as herringbone, help to distribute horizontal loads. In areas subjected to heavy vehicular traffic, the brick pavers may be required to have a minimum thickness to achieve sufficient interlock.

Adequate design and construction results in three types of interlock: vertical interlock, rotational interlock, and horizontal interlock. See Figure 2. If a vertical load were applied to a single brick in a pavement without vertical interlock, that brick would be forced down between adjacent bricks, transmitting concen-

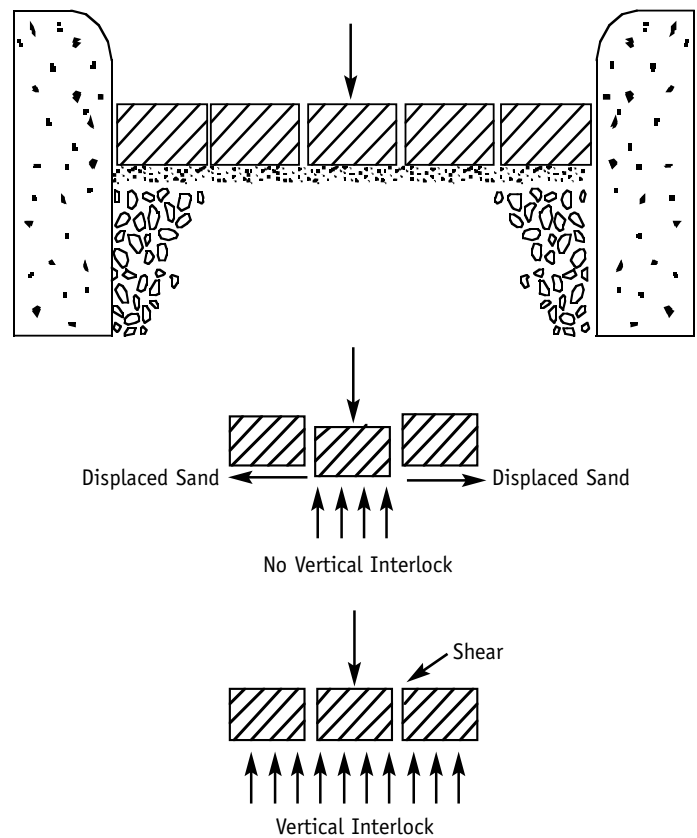

Figure 2: Vertical Interlock

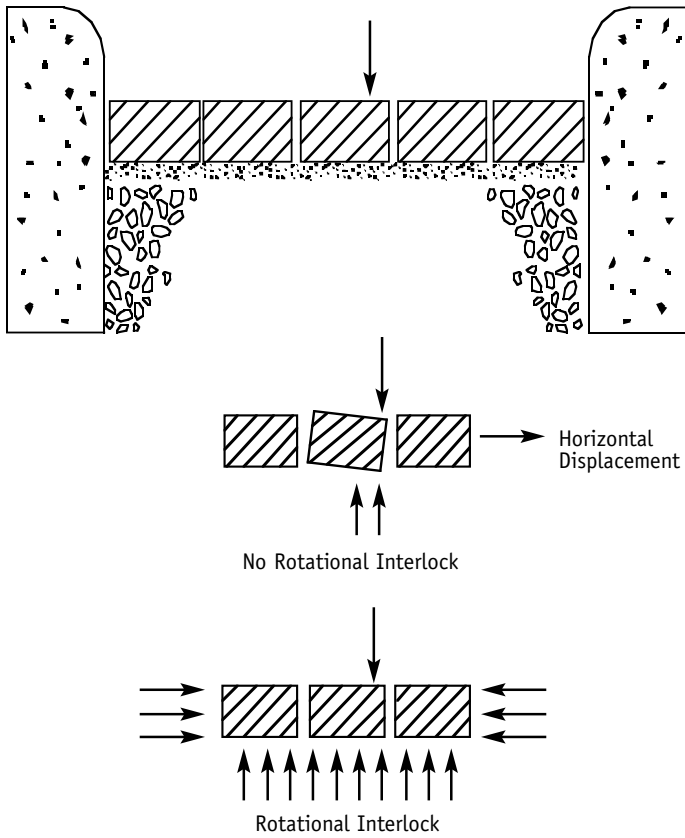

Figure 3: Rotational Interlock

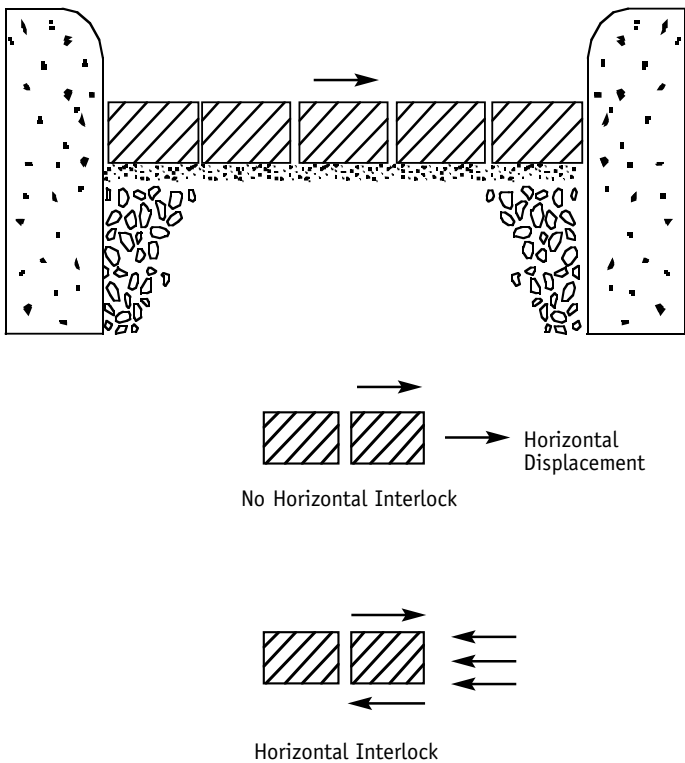

Figure 4: Horizontal Interlock

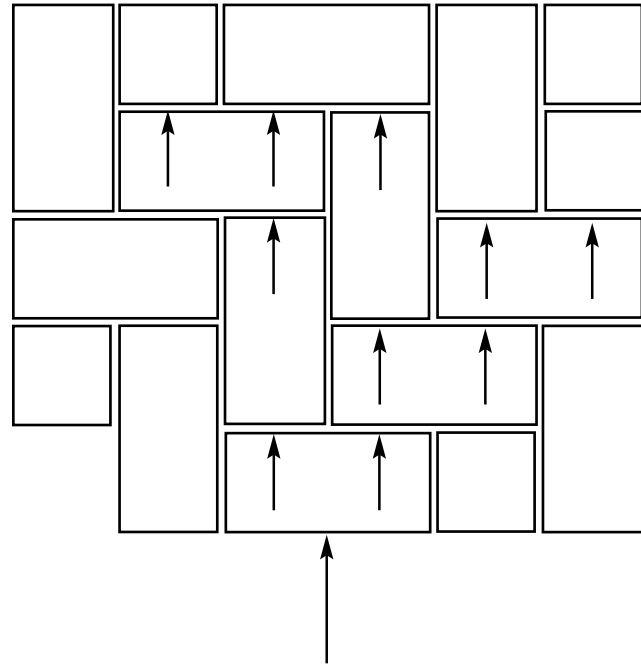

Figure 5: Horizontal Load Interlock

trated stresses onto the setting bed. Brick pavers that are compacted into the setting bed and have well consolidated sand in the joints between them provide shear resistance in the wearing surface. Thus, the load is spread over a wide area of setting bed. See Figure 2. Sand set pavers develop greater vertical interlock than bituminous set pavers as they are vibrated to compact the sand bed and densify the joint sand to a higher degree.

If a load is applied asymmetrically to an individual brick, the brick may rotate, displacing the setting bed and adjacent bricks. Rotational interlock holds the brick in place while rigid edge restraints prevent the bricks from moving laterally, thereby eliminating rotation. See Figure 3.

Horizontal interlock is not achieved if horizontal movement is allowed. In vehicular traffic areas, horizontal braking, cornering and accelerating forces try to move pavers along the road; this is known as creep. Sand filled joints and an interlocking bond pattern transfer these forces within a paving area to rigid edging. See Figure 4. Loads created by turning vehicular traffic are distributed more evenly in all directions by a herringbone pattern than by running bond pattern, which has acceptable horizontal interlock in only one direction. See Figure 5. Basket weave patterns may have continuous joints in two directions, resulting in unacceptable horizontal interlock. Sand set brick pavers initially develop greater horizontal interlock than bituminous set brick pavers as the joint sand is better compacted.

TABLE 1: Brick Paving System Selection Guide

System	Advantages	Disadvantages
Flexible brick paving over flexible base (Fig. 6a)	<ul style="list-style-type: none"> • Most durable over time • Easy to repair utilities • Usually most economical • Allows use of semi-skilled labor 	<ul style="list-style-type: none"> • May require a thicker base • Permits some water percolation through system
Flexible brick paving over semi-rigid base (Fig. 6b)	<ul style="list-style-type: none"> • Good as an overlay to existing pavement • Good over poor soils or small, confined areas • Better aesthetic repairs than asphalt 	<ul style="list-style-type: none"> • Slightly more expensive
Flexible paving over rigid base (Fig. 6c)	<ul style="list-style-type: none"> • Good as an overlay to existing pavement • Good over poor soils or small confined areas • Better aesthetic repairs than continuous concrete 	<ul style="list-style-type: none"> • Requires good drainage • More expensive • Vulnerable to frost heave
Sand setting system	<ul style="list-style-type: none"> • Good load transfer • Simple and expedient installation • Pavers easily reused for repairs 	<ul style="list-style-type: none"> • Susceptible to deficiencies in the bedding sand • Susceptible to sand loss and creep issues
Bituminous setting system	<ul style="list-style-type: none"> • Enhanced water resistance • Good containment of setting bed material • Less onerous edge restraint requirements 	<ul style="list-style-type: none"> • More expensive and slower to install • Pavers difficult to salvage during repair work • Poor tolerance to paver thickness variations or poor base elevations
Mortared paving over rigid base (Fig. 6d)	<ul style="list-style-type: none"> • Matches adjacent walls with mortar joints • Good over poor soils • Can be used on steeper grades 	<ul style="list-style-type: none"> • Must have a concrete base • Most costly of all brick paving • Requires maintenance of mortar joints • Requires movement joints

Although a flexible brick pavement provides a durable surface for light or heavy vehicular applications, the surface of a segmental pavement may not provide a smooth ride at high speeds. Brick roads tend to slow traffic as subtle variations in the surface cause decreasing ride comfort as speed increases. These variations help reduce speeds in areas where faster vehicular traffic may be a concern. This is one of many traffic calming measures that cities use

to slow traffic in residential neighborhoods. However, segmental pavements are not recommended where vehicle speeds exceed 40 mph (64 kph).

Deciding on the appropriate brick paving system to use is important to ensure proper performance. Since brick can be used in a variety of ways, as shown in Figure 6, Table 1 is provided to assist in selecting the most appropriate system.



Figure 6: Brick Paving Systems

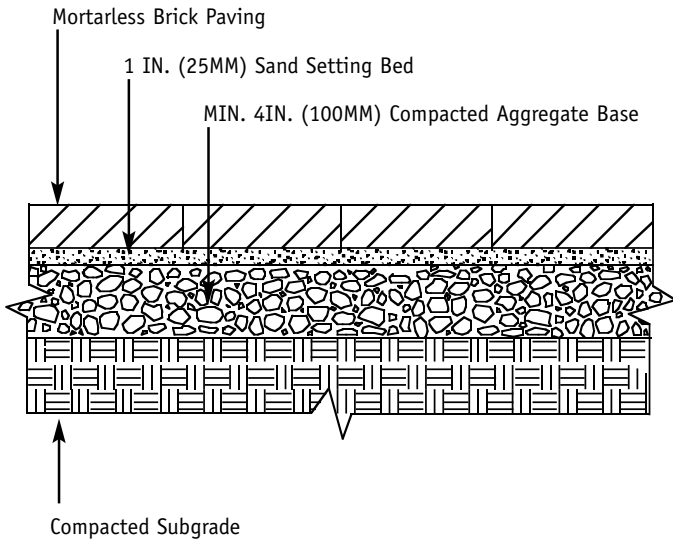

**Figure 6a: Mortarless Brick Paving
Aggregate Base**

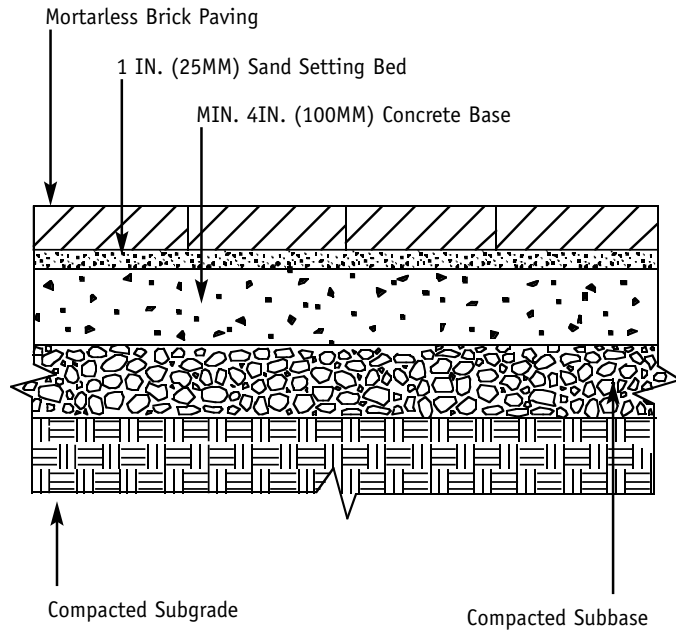

**Figure 6c: Mortarless Brick Paving
Concrete Base**

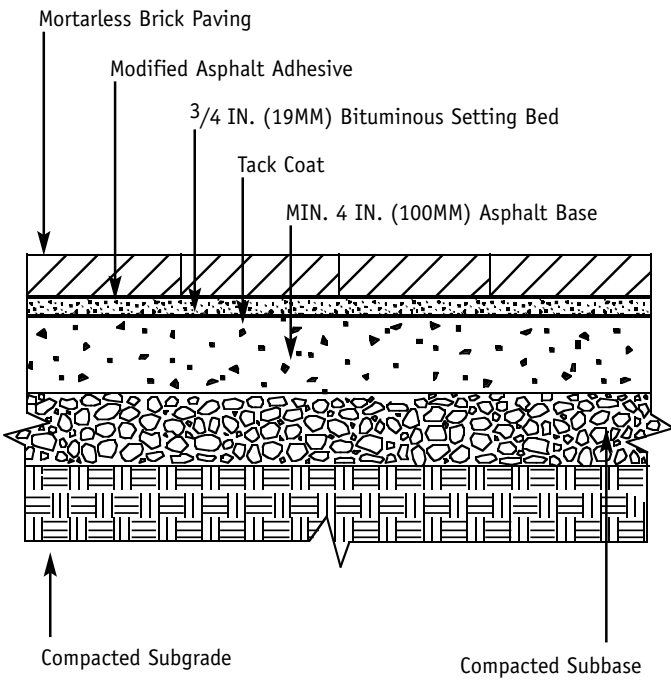

**Figure 6b: Mortarless Brick Paving
Asphalt Base**

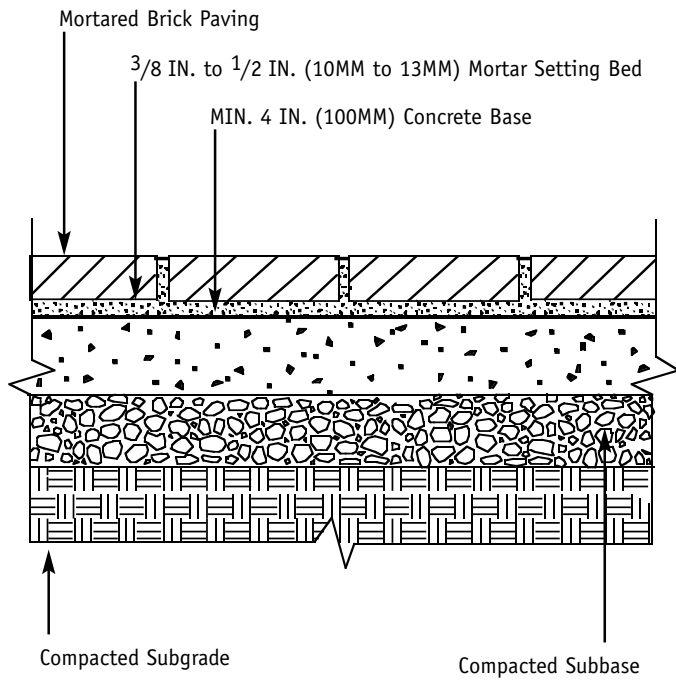

**Figure 6d: Mortared Brick Paving
Concrete Base**

Part I: Structural Design

Introduction

The AASHTO methodology was described in detail in the first edition of this Guide. Direction was given on determining the amount of traffic that would use the pavement, dependent on the many factors identified in the 1993 AASHTO Design Guide. Tables were provided for calculating the estimated traffic in the design lane based upon axle loads, equivalency factors, structural numbers, growth factors and lane distribution factors. The equations used to calculate the required structural number for the pavement, and to proportion the individual pavement layers were set out, along with figures and tables to assess the layer and drainage coefficients necessary to design the pavement. In addition, nomographs and design examples were provided to clarify the procedure.

This version of the Guide provides a method based upon specific applications and site conditions rather than the more complex procedure of the first edition. The design solutions were prepared in accordance with the AASHTO methodology, and the input values are declared in the relevant sections. Although the proposed pavement sections may be appropriate in developing preliminary sections and budget costs, it is recommended that the final design be certified by an engineer with pavement design experience.

In addition to these revisions related to the AASHTO design method, this edition also discusses an alternative design method for use in those states that have adopted the Caltrans design method or derivations thereof. Design solutions are not provided using this method, but gravel equivalent factors are suggested for use with the Caltrans manual, so that it can be adapted to consider brick pavers.

Because of the range of climates and the variability of soils, base and subbase materials, designers must use good engineering judgment in detailing a flexible brick paving system. The designer should be acquainted with site conditions and use all available resources to create a cost-effective solution. Consult references listed at the end of this Guide for more information.

Subgrade Classification

The subgrade is classified by the existing soil conditions, the environment and drainage. The more accurate the subgrade classification, the better the performance of the pavement.

Soil Conditions

The existing soil conditions for a project should be determined prior to commencing the design of the pavement sections. A geotechnical engineer who specializes in site investigation work will generally test and classify the soil conditions for the project area. Testing will be carried out at the project site and samples will be recovered for additional testing in the laboratory.

The site investigation should include test pits and borings along the alignment of the road or street, or over the area of the pavement. Samples should be collected for the following laboratory tests considered essential to determine the

engineering properties of the soils over which the pavement will be constructed:

- Grain-size distribution: sieve analysis test and hydrometer test to determine the percentage of the individual grain sizes in the sample;
- Atterberg Limits: consistency tests to determine the moisture content at which the sample changes from a semi-solid state to a plastic state (Plastic Limit) and from a plastic state to a liquid state (Liquid Limit);
- Natural moisture content: test to determine the in-place moisture content of the soil;
- Natural Density: test to determine the in-place density of the soil;

n and Detailing

- Dry density/optimum moisture content relationship (standard or modified): compaction test to determine the ideal moisture content to achieve the specified state of compaction;
- Strength tests [California Bearing Ratio (CBR) or Resistance Value (R-value)]: mechanical tests to determine the bearing capacity of the soil for use in the design.

The CBR test method is set out in ASTM D 1883 Test Method for CBR of Laboratory Compacted Soils (AASHTO T193). It can be conducted on treated and untreated base, subbase and subgrade materials. This test is a comparative measure of the load-bearing capacity of a soil. It measures the load required to drive a standard plunger a set depth into a sample of soil at a standard rate of penetration. The CBR value is the ratio of the load measured in the test and the load used to achieve the same penetration in a standard sample of crushed stone. The test is generally undertaken in the laboratory, but in-place tests can also be carried

out. The values are greatly affected by the degree of compaction and the moisture content of the specimen. The test should be conducted on a specimen compacted to a density representative of the material to be used in the pavement, or alternatively at a range of densities likely to be encountered. To represent the material's potential moisture condition in the pavement, the test should be conducted on specimens that have been soaked after compaction for a period of four days.

The R-value test method is set out in ASTM D 2844 Test Method for Resistance R-Value and Expansion Pressure of Compacted Soils (AASHTO T190). It can be conducted on treated and untreated base, subbase and subgrade materials, but the test can only be undertaken in the laboratory. For base, subbase and non-expansive granular soils, the R-value is determined at a density equivalent to the density used during construction. For cohesive soils and expansive granular materials, the R-value test involves two separate

procedures. One procedure calculates the estimated thickness of the overlying pavement layers required to maintain the state of compaction of the material. The other procedure estimates the thickness of the overlying pavement layers required to prevent plastic

deformation in the material. The R-value is determined at the moisture content and density at which the thickness of overlying materials is similar in the two procedures.

The AASHTO design method uses the resilient modulus (M_R) as the design input for the subgrade properties. The mean value of all test results for each pavement section or soil type should be used for design. The test to directly determine M_R is not widely used, so AASHTO has proposed the following relationships between the CBR and R-value test results. These relationships are as follows:

$$M_R \text{ (MPa)} = 10.3 \times \text{CBR} \quad \text{(Eq. 1)}$$

Where: M_R is the resilient modulus
and CBR is the California Bearing Ratio

$$M_R \text{ (MPa)} = 6.9 + 3.8 \times \text{R-value} \quad \text{(Eq. 2)}$$

The Caltrans design method uses the R-value as the design input for the subgrade properties. The lowest R-value should be used for design over a section of pavement. However, if there are one or two significantly lower R-values in a localized section, consideration should be given to replacing these areas with better material and using the next lowest value.

This Guide provides design solutions based on five subgrade categories as set out in Table 2. The table provides CBR and R-values for each subgrade category, based upon relationships to the resilient modulus value M_R as set out in Equations (1) and (2). Soils with a CBR value of less than 3.0 or R-value of less than 6 require some form of improve-

TABLE 2: Subgrade Categories

Subgrade Category	CBR Range	R-value Range
Unsuitable	< 2.9	< 6
Poor	3.0 - 5.9	6 - 13
Fair	6.0 - 9.9	14 - 24
Good	10.0 - 14.9	25 - 38
Excellent	> 15.0	>38

M145, Classification of Soils and Soil-Aggregate Mixtures for Highway Construction.

In the USCS, the soils are classified in twenty-five groups by two letter designations dependent on the soil type and physical properties. The first letter rep-

are classified in seven main groups (and in twelve sub-groups) based upon their grain-size distribution and Atterberg Limits. The two systems are given in Tables 3 and 4, in a manner that correlates each group with the suggested subgrade categories (U -unsatisfactory, P - poor, F - fair, G - good, E - excellent).

TABLE 3: Subgrade Categories from USCS

USCS Designation	Environmental/Drainage Conditions			
	Wet	Average	Dry	Frost
GW	E	E	E	E
GP	E	E	E	E
GW-GM	E	E	E	G
GW-GC	E	E	E	G
GP-GM	E	E	E	G
GP-GC	E	E	E	G
GM	E	E	E	P
GC`	E	E	E	P
GM-GC	E	E	E	P
SW	E	E	E	E
SP	G	E	E	E
SW-SM	G	E	E	F
SW-SC	G	E	E	F
SP-SM	G	E	E	F
SP-SC	F	G	E	F
SM	G	E	E	U
SC	F	G	E	P
SC-SM	G	E	E	U
CL	P	F	G	P
CL-ML	P	F	G	U
ML	P	F	G	U
OL	U	U	U	U
CH	P	P	F	P
MH	P	F	F	U
OH	U	U	U	U

A geotechnical engineer’s report will include a description of the soils encountered at the project site and will set out the test results. In addition, it will generally provide recommendations on the strength properties of the soils to be used for design and may contain some design options for the pavement section. If a recommended value is given in the report, this should be used to select the subgrade category (see Table 2). If there is no recommended value, but CBR or R-value test results are given, the average of these values should be used for the AASHTO design methodology. When the design is to be undertaken using the Caltrans adaptation, the minimum R-value should be used for selecting the subgrade category. If only the subgrade’s USCS or AASHTO classification is known, Table 3 or 4 can be used to estimate the subgrade category from the column titled “Average”. The remaining columns are addressed in the following section.

ment that is beyond the scope of this Guide. They are considered unsuitable as a subgrade.

Soils or subgrades are typically classified into different groups to represent their engineering properties. There are several systems used in the United

States, but the two most common are the Unified Soil Classification System (USCS), used for general engineering purposes, and the AASHTO System, used for highway engineering purposes. The USCS is set out in ASTM D 2487 and the AASHTO system is set out in AASHTO Standard

represents the main soil type (gravel, sand, silt, clay or organic), and the second modifies the first letter based upon the grain-size distribution for granular soils or the Atterberg Limits for cohesive soils. Eleven groups have paired designations. In the AASHTO system, the soils

Environment and Drainage

Environmental conditions and the quality of subgrade drainage can have a major effect on the support offered by the subgrade. In wet climates, poorly drained areas, or those that experience freezing conditions, the subgrade support is likely to be reduced during certain periods of the pavement’s life. Conversely, in arid climates or well-drained areas, it is likely that a higher degree of subgrade support will be experienced during part of the pavement’s life. These factors can have a significant effect on the performance of the pavement.

Saturation of the subgrade, and the materials in the pavement section, can lead to premature distress as this condition reduces the strength of these materials. Water can enter the pavement through the joints between bricks, through cracks and joints in the bound base materials, or from a high ground water condition. The amount of water penetrating from the surface depends on the regional climate. Fluctuations in moisture content can also be problematic, leading to changes in volume and load support. Rapid removal of water from the pavement is therefore an important design objective, and a positive drainage system should be considered. Design of such a system is beyond the scope of this Guide.

Figure 7 presents the six climatic regions experienced in the United States. It depicts two regions of hard freezes where spring thaw conditions are likely

to affect the subgrade, two regions where there is a potential effect from frost, but only if the pavement is thin, and two regions not susceptible to frost. Average depths of frost penetration are indicated for the eastern and central states, although frost depths can vary locally based on many factors. Local data should be used in its place if this is available for a specific project site. This is particularly true in the western states, and no frost depth data is therefore included in Figure 7 for this part of the country. If the depth of frost penetration is greater than the pavement thickness determined in this Guide based on one of the first three columns of Tables 3 and 4, it will be necessary to revise the pavement construction. Either non-frost susceptible material should be added to the thickness of the pavement section so that it is thicker than the depth of penetration, or a revised depth should be

determined based upon the anticipated loss of strength in the subgrade. In this case, if the project is located in Regions III or VI on Figure 7, it will be necessary to use the subgrade category from the column for Frost Environmental/ Drainage Conditions. If the project is located in Regions II or V, and the project site drains poorly, it will also be necessary to use the Frost Environmental/ Drainage Conditions column to determine the subgrade category, since, once again, pavement thickness is a factor.

The AASHTO design method utilizes an effective resilient modulus that is derived from the seasonal resilient moduli. These vary depending on the moisture conditions of the subgrade during each season. Such an analysis is beyond the scope of this Guide. It is recommended that the design be undertaken using a subgrade category as described earlier or from the geotechnical report, as the geotechnical consultants

will consider these factors when providing their recommendations. If these values are not available, but the USCS or AASHTO designation is known, Tables 3 and 4 should be used to develop the appropriate subgrade category. Most pavements should be designed using the subgrade category from the column for Average Environmental/Drainage Conditions. However, if the project is located in Regions I, II or III of Figure 7, and the project site drains poorly, such that the subgrade is frequently saturated, it will be necessary to use the subgrade category from the column for Wet Environmental/Drainage Conditions. If the project is located in Regions IV, V or VI and the project site drains well, such that the subgrade is rarely saturated, it may be appropriate to use the column for Dry Environmental/ Drainage Conditions.

TABLE 4: Subgrade Categories from AASHTO

AASHTO Designation	Environmental/Drainage Conditions			
	Wet	Average	Dry	Frost
A-1-a	E	E	E	E
A-1-b	E	E	E	G
A-2-4	E	E	E	U
A-2-5	E	E	E	U
A-2-6	F	G	E	P
A-2-7	G	E	E	P
A-3	G	E	E	F
A-4	P	G	E	U
A-5	P	P	F	U
A-6	P	F	G	P
A-7-5	P	P	F	P
A-7-6	P	F	G	P

Traffic Analysis

The traffic analysis for the project should be undertaken before commencing design of the pavement sections. A traffic engineer is typically contracted for this work. When undertaking a design it is necessary to determine the existing (or initial) traffic volume using the road, and to estimate the future traffic volumes over the analysis period. Based upon these data and local experience, it is necessary to establish the traffic flow in each direction and in the design lane. Most of the damage to a pavement is caused by truck traffic; passenger cars, pick-ups and light two axle trucks generally have a negligible effect. Using local data on the anticipated types of vehicles that will use the road, the number of load applications of each axle group can be calculated. Next, all of the repetitions of each axle group are converted into the equivalent number of repetitions of one axle load condition.

In this Guide, a simplified approach is adopted using pavement classes. Nine pavement classes are identified in Table 5, together with a description of their anticipated use and an indication of the total number of ESALs and TI for each class.

The life of the pavement can be expressed in a number of ways depending on local policy. Two terms are used in the AASHTO Design Guide covering different long-term strategies. These are the performance period and the analysis period. The performance period is the length of time that a pavement will remain serviceable before it requires rehabilitation such as an overlay. The analysis period is the amount of time over which the pavement life is to be considered, including any rehabilitation work. For high volume roads (collectors and above), an analysis period of at least thirty years is frequently considered. For low volume roads (locals and below) and all other pavements, a twenty-year life is generally acceptable. As rehabilitation of flexible brick pavements cannot be achieved by strengthening measures without lifting the bricks, this Guide considers the analysis period as the design life of the pavement.

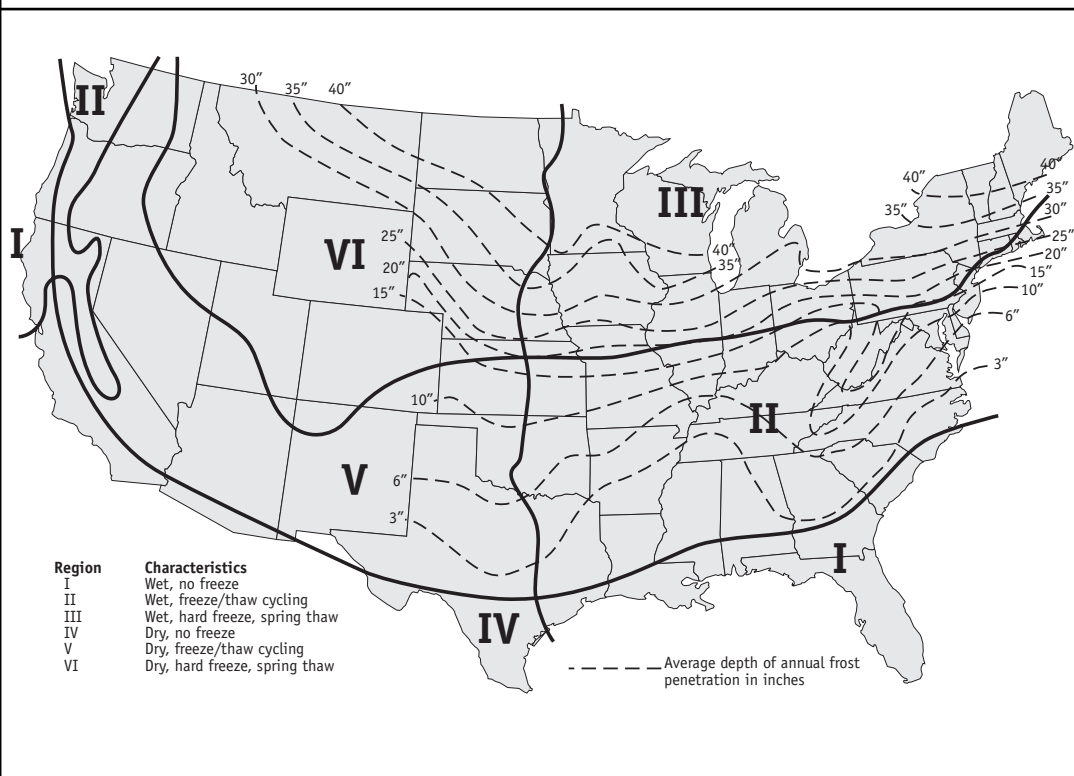

Figure 7: Climatic Regions in the United States and Average Depth of Annual Frost Penetration

In the AASHTO design methodology, the traffic is represented as the equivalent number of load applications of an 18-kip axle load that represents the mixed traffic using the pavement. This is known as an equivalent single axle

load (ESAL). Tables in the AASHTO Design Guide provide values for converting different axle loads into ESALs.

In the Caltrans method, this number of ESALs is further converted into a

traffic index (TI). This varies in accordance with Equation 3 below, except that the TI is rounded to the nearest 0.5:

$$TI = 9.0 \times (ESAL/10^6)^{0.119} \quad (\text{Eq. 3})$$

TABLE 5: Pavement Class Description and Traffic

Pavement Class	Description	Design ESALs	TI
PC-1 Arterial or Major Street	Through traffic with access to high-density, regional, commercial and office developments, or downtown streets. General traffic mix.	9,000,000	11.5
PC-2 Major Collector	Through traffic with access to low-density, local, commercial and office development or high density, residential sub-divisions. General traffic mix.	3,000,000	10.0
PC-3 Minor Collector	Through traffic with access to low-density, neighborhood, commercial development or low-density, residential sub-divisions. General traffic mix.	1,000,000	9.0
PC-4 Public Transport Interchange or Bus Parking	Centralized facility for buses to pick up passengers from other modes of transport, or for parking of city or school buses.	500,000	8.5
PC-5 Commercial and Residential Local	Limited through traffic with access to commercial premises and multi-family and single-family residential roads. Used by private automobiles, service vehicles and heavy delivery trucks.	330,000	8.0
PC-6 Residential Access	No through traffic with access to multi-family and single-family residential properties. Used by private automobiles, service vehicles and light delivery trucks, including limited construction traffic.	110,000	7.0
PC-7 Facility Parking	Open parking areas for private automobiles at large facilities with access for emergency vehicles and occasional use by service vehicles or heavy delivery trucks.	90,000	7.0
PC-8 Business Parking	Restricted parking and drop-off areas associated with business premises, mostly used by private automobiles and occasional light delivery trucks. No construction traffic over finished surface.	30,000	6.0
PC-9 Commercial Plaza	Predominantly pedestrian traffic, but with access for occasional heavy maintenance and emergency vehicles. No construction traffic over finished surface.	10,000	5.0

AASHTO Design Concepts

The AASHTO Design Guide is based upon empirical test results from full-scale road tests conducted in the 1960's. As a result of the measured behavior of the test sections, the researchers developed a performance equation upon which design of new pavement sections can be achieved. The equation relates the design life, in terms of 18 kip ESALs, to a number of different input parameters. These include the reliability of the pavement, the acceptable level of loss in serviceability, the variability of the traffic predictions and performance, the structural number and the average subgrade resilient modulus.

The reliability of the designed pavement section is an important feature in the AASHTO design process. The reliability of the pavement is the probability that it will perform satisfactorily over its design life for the traffic and environmental conditions experienced. The reliability level adopted in this Guide is taken as an 85 percent likelihood that the pavement will reach its design life (analysis period) for pavements with high traffic volumes (collectors and above); and a 75 percent likelihood that the pavement will reach its intended design life for pavements with low traffic volumes (locals and below).

Non-highway pavements are also considered to have a reliability of 75 percent. This means that 85 percent or 75 percent of the pavements for each respective use would achieve or exceed the design life.

The AASHTO design method uses a subjective measure of the loss of serviceability and failure of the pavement. It was developed as an interpretation of the quality of the ride experienced by the average road user. A scale from 0 to 5 represents the quality of the ride and is known as the Present Serviceability Index (PSI). A PSI of 0 represents an impassable road while a PSI

of 5 represents a perfect road. The change between the initial and final (terminal) PSI, known as the Serviceability Loss, used in this Guide is taken as 1.7 for high traffic volumes and 2.2 for low traffic volumes. This is based upon an initial value of 4.2 and terminal values of 2.5 and 2.0 respectively. This compares favorably with those used for typical flexible pavements. An exception is in pedestrian areas where the potential for trip hazards is an important consideration. Therefore, a serviceability loss of 1.7 is recommended in these locations. Other AASHTO reliability parameters are presented in Table 6.

The variability of the traffic prediction and pavement performance is taken as 0.35. This is comparable with the figures used for flexible pavements using asphaltic concrete as a surface course.

The structural number is the only parameter directly related to the pavement section. It is derived from the layer coefficient of each layer, the thickness of each layer, and the drainage coefficient for each layer. This Guide is produced under the assumption that adequate drainage will be provided to the pavement materials such that the latter coefficient can be taken as 1.0. Typical layer coefficients are presented in Table 7, with the default values used in subsequent design tables in this Guide.

The values presented in Table 7 can be used to adjust the layer thicknesses derived from the design tables. The ratio of the layer coefficients can be used to determine the equivalent thickness of an alternative material. For example, to include a 6-in. (150 mm) thick lime stabilized subbase it is possible to reduce the aggregate base by 0.11/0.14 times the 6-in. (150 mm) thickness, i.e. by 4.5 in. (114 mm). Similarly, to replace 8.5 in. (216 mm) of graded crushed aggregate (CBR 100) with graded aggregate (CBR 60) multiply 8.5 by 0.14/0.12, i.e. replace with 10 in. (254 mm) of graded aggregate. However, it is recommended that the top of the aggregate base directly under the paver setting bed always be constructed with graded, crushed material that is 4 in. (100 mm) thick when the ESALs are below 500,000 or 6 in. (150 mm) thick when the ESALs are at 500,000 and above respectively.

AASHTO Design Solutions

Tables 8 through 11 of this Guide have been prepared to provide design solutions to each pavement class and subgrade category. The wearing surface is always a 2-5/8 in. (67 mm) paver on a 1 in. (25 mm) setting bed. The bituminous setting bed is usually specified at 3/4 in. in thickness, and an adjustment to the developed thicknesses is required as discussed in the bituminous setting bed section. The base is as indicated in the tables.

Table 8 presents the thickness of graded aggregate subbase course required for each application. The resultant pavement section will be comprised of 2-5/8 in. (67 mm) thick flexible brick surface on 1 in. (25 mm) of bedding sand, over 4 in. (100 mm) of crushed, graded aggregate base on top of the thickness of graded aggregate subbase determined from the table. Note that the thickness of crushed, graded aggregate base is increased from 4 in. to 6 in. (100 to 150 mm) for traffic levels over 500,000 ESALs. An unbound base course is not considered appropriate for traffic levels above 2,000,000 ESALs.

Similarly, Table 9 provides the required thickness of graded aggregate subbase when a cement treated base is used under the bedding sand. Note that in this case the thickness of cement treated base is increased from 4 in. to 6 in. (100 to 150 mm) for traffic levels over 2,000,000 ESALs. Table 10 can be used when an asphalt treated base is provided.

Table 11 provides typical portland cement concrete slab thicknesses, with a 4 in. (100 mm) aggregate subbase below and a wearing surface of flexible brick paving. This table is for guidance if the bricks are to be used over such a substrate. Little structural benefit is provided by the bricks in this pavement section, and care needs to be exercised in ensuring that detailing allows for thermal and moisture induced movement in the concrete, and for egress of moisture penetrating the brick surface.

TABLE 6: AASHTO Reliability Parameters

Pavement Class	Reliability	Serviceability Loss
PC-1	0.85	1.7
PC-2	0.8	1.7
PC-3	0.85	1.7
PC-4	0.75	1.7
PC-5	0.85	2.2
PC-6	0.75	2.2
PC-7	0.75	2.2
PC-8	0.75	2.2
PC-9	0.75	1.7

TABLE 7: Layer Coefficients

Pavement Layer	Pavement Material or Property	Layer Coefficient
Pavers on sand setting bed	(increases with traffic volume)	0.31 to 0.40
Pavers on bituminous setting bed	(increases with traffic volume)	0.30 to 0.37
Cement-treated base	7 day compressive strength 800 psi	0.22
	7 day compressive strength 650 psi	0.20 (default)
	7 day compressive strength 500 psi	0.17
Asphalt-treated base	Marshall stability 1,800 lbs	0.32
	Marshall stability 1200 lbs	0.26 (default)
	Marshall stability 750 lbs	0.20
Aggregate base	graded crushed aggregate (CBR 100)	0.14 (default)
	graded aggregate (CBR 60)	0.12
Subbase	graded aggregate (CBR 30)	0.11
	cement-stabilized subgrade (250 psi)	0.13
	lime-stabilized subgrade (150 psi)	0.11



TABLE 8: Graded Aggregate Subbase Thickness Under 4 in. Graded, Crushed Aggregate Base

Pavement Class	ESALs	TI	Subgrade Category			
			Poor	Fair	Good	Excellent
PC-1 Arterial or Major Street	9,000,000	11.5	N.A.	N.A.	N.A.	N.A.
PC-2 Major Collector	3,000,000	10.0	N.A.	N.A.	N.A.	N.A.
PC-3 Minor Collector	1,000,000	9.0	15.0*	7.0*	4.0*	0.0*
PC-4 Public Transport Interchange or Bus Parking	500,000	8.5	9.5*	4.0*	4.0*	0.0*
PC-5 Commercial or Residential Local	330,000	8.0	10.5	4.5	4.0	0.0
PC-6 Residential Access	110,000	7.0	5.5	4.0	0.0	0.0
PC-7 Facility Parking	90,000	7.0	4.5	0.0	0.0	0.0
PC-8 Business Parking	30,000	6.0	4.0	0.0	0.0	0.0
PC-9 Commercial Plaza	10,000	5.0	4.0	0.0	0.0	0.0

* with 6 in. graded, crushed aggregate base

TABLE 9: Graded Aggregate Subbase Thickness Under 4 in. Cement-Treated Base

Pavement Class	ESALs	TI	Subgrade Category			
			Poor	Fair	Good	Excellent
PC-1 Arterial or Major Street	9,000,000	11.5	24.5*	15.0*	9.0*	6.0*
PC-2 Major Collector	3,000,000	10.0	18.0*	9.0*	6.0*	6.0*
PC-3 Minor Collector	1,000,000	9.0	15.0	7.5	4.0	4.0
PC-4 Public Transport Interchange or Bus Parking	500,000	8.5	10.0	4.0	0.0	0.0
PC-5 Commercial or Residential Local	330,000	8.0	8.5	4.0	0.0	0.0
PC-6 Residential Access	110,000	7.0	4.0	0.0	0.0	0.0
PC-7 Facility Parking	90,000	7.0	4.0	0.0	0.0	0.0
PC-8 Business Parking	30,000	6.0	4.0	0.0	0.0	0.0
PC-9 Commercial Plaza	10,000	5.0	4.0	0.0	0.0	0.0

* with 6 in. cement treated base

TABLE 10: Graded Aggregate Subbase Thickness Under 3 in. Asphalt-Treated Base

Pavement Class	ESALs	TI	Subgrade Category			
			Poor	Fair	Good	Excellent
PC-1 Arterial or Major Street	9,000,000	11.5	26.0*	16.5*	10.0*	6.0*
PC-2 Major Collector 3,000,000	10.0	19.0*	10.5*	6.0*	6.0*	
PC-3 Minor Collector 1,000,000	9.0	15.5	7.5	4.0	4.0	
PC-4 Public Transport Interchange or Bus Parking	500,000	8.5	10.0	4.0	0.0	0.0
PC-5 Commercial or Residential Local	330,000	8.0	8.5	4.0	0.0	0.0
PC-6 Residential Access	110,000	7.0	4.0	0.0	0.0	0.0
PC-7 Facility Parking 90,000	7.0	4.0	0.0	0.0	0.0	
PC-8 Business Parking	30,000	6.0	4.0	0.0	0.0	0.0
PC-9 Commercial Plaza	10,000	5.0	4.0	0.0	0.0	0.0

* with 4 in. (150mm) asphalt treated base

TABLE 11: Concrete Slab Thickness with 4 in. Aggregate Subbase

Pavement Class	ESALs	TI	Subgrade Category			
			Poor	Fair	Good	Excellent
PC-1 Arterial or Major Street	9,000,000	11.5	10.5	10.0	9.5	9.5
PC-2 Major Collector	3,000,000	10.0	9.0	8.5	8.0	7.5
PC-3 Minor Collector	1,000,000	9.0	7.0	6.5	6.0	5.5
PC-4 Public Transport Interchange or Bus Parking	500,000	8.5	6.0	5.5	4.0	4.0
PC-5 Commercial or Residential Local	330,000	8.0	5.5	5.0	4.0	4.0
PC-6 Residential Access	110,000	7.0	5.5	4.0	4.0	4.0
PC-7 Facility Parking	90,000	7.0	4.0	4.0	4.0	4.0
PC-8 Business Parking	30,000	6.0	4.0	4.0	4.0	4.0
PC-9 Commercial Plaza	10,000	5.0	4.0	4.0	4.0	4.0

CALTRANS Design Concepts

The Caltrans design method is also based upon a wide range of information including: theory, test track studies, experimental pavement sections, observations of pavement performance, and research on materials. Pavements are generally designed for a twenty year life, but it is accepted that asphalt concrete surfaced pavements will require maintenance at ten to fifteen years if they are to achieve this life. This is generally a surface material issue, and this Guide assumes that the brick pavers will provide a twenty year life.

The Caltrans design method considers the various pavement materials in terms of a gravel factor (Gf). Tables are included in the Caltrans design manual setting out the gravel factors for various materials dependent on the materials properties and the TI. The gravel factor is a representation of the relative ability of the materials to resist the effects of traffic loading, when compared to an equivalent thickness of gravel.

The design of the pavement section is based upon a relationship between the R-Value (R), and the Traffic Index (TI) to develop the Gravel Equivalent (GE) for the pavement. The relationship is represented by Equation 4:

$$GE \text{ (mm)} = 0.975 \times (TI) \times (100 - R) \text{ (Eq. 4)}$$

The procedure is carried out from the top of the pavement to the bottom. Treated base layers generally have an R-value greater than 100 and so the equation is typically applied to

the highest layer in the pavement section with an R-value less than 100. The thickness of the overlying layers is determined. The process is then used for the underlying layer, and so on down to the subgrade. The thickness of each layer is calculated by dividing the GE by the appropriate Gf. The thickness of each layer is generally rounded to the next 0.05 ft (15 mm) increment.

To allow for deviations from the specified thickness as a result of construction procedures the Caltrans method uses a safety factor procedure. This involves adding 0.2 ft (60 mm) to the GE of the asphalt concrete surface material and subtracting 0.2 ft (60 mm) from the GE of the subbase, or if no subbase is used, from the thickness of the base. The thickness of the brick pavers cannot be changed, and so this practice needs to be undertaken between the base and the subbase, if used.

Design solutions using the Caltrans procedure are not presented in this Guide, however, a Gf of 2.0 is proposed for the brick paver and sand setting bed, and 1.8 is proposed for the brick pavers on a bituminous setting bed, based upon the above noted typical relationship with equivalency to asphalt concrete. This value can be used when the Caltrans manual is appropriate for the design, rather than the AASHTO methodology.

Design of Bituminous Setting Bed Systems

Bituminous setting bed systems as shown in Figure 6b can be used in most of the same applications as sand setting bed systems. Higher speed applications are less desirable as the interlock between pavers is reduced. Although it has reduced structural benefits, the system can provide better moisture protection to the underlying layers. In addition, the bonding action of the system enables the use of pavers with a lower standard of dimensional tolerances where wider joints would lead to reduced “lock-up” in a sand set system. Joint widths of up to 1/4 inch (6 mm) can be tolerated, especially in low traffic applications. As there is no vibration used to compact the pavers, chipping is less of a problem, particularly with pavers that do not have chamfers or lugs. This system may also have advantages where edge restraints are less reliable, or where movement may be encountered. This typically occurs where pavers are placed against steel rails for light rail applications.

The bituminous setting bed system can be used as an alternative to a sand setting bed system. The 1 in. (25 mm) thick sand setting bed is replaced by a 3/4 in. (19 mm) thick asphalt coated sand mixture that is “bonded” to the underlying pavement layer using a tack coat. The brick pavers are bonded onto this layer with a rubberized asphalt adhesive. The joints are filled with stabilized sand, but no vibration is used. Consequently, “lock-up” is not as well established and the load spreading is reduced. The base thicknesses presented in this Guide can be used for this system; however, the thickness of the underlying layers needs to be increased. This can be achieved by adding an additional 1 in. (25 mm) to the thickness of the cement treated base layer, 3/4 in. (19 mm) to the thickness of the

asphalt treated base layer, or 1-1/2 in. (38 mm) to the thickness of the graded, crushed aggregate base. No revision is necessary for the portland cement concrete sub-slab option.

Mortared Brick Paving

The structural design of mortared brick paving follows the design of rigid pavements. The brick pavers and the mortar setting bed are not taken into account in the thickness design. The design of mortared brick paving is not the aim of this Guide. Refer to the AASHTO Design Guide or BIA *Technical Notes* 14 Series.

Detailing Surface Profile

Satisfactory slopes for flexible paving must be provided to avoid ponding water. A minimum slope of 2 percent, (1/4 in. per foot or 1 mm per 50 mm), is suggested for all exterior brick paving. Crowns on roads usually provide adequate slope. A maximum slope of 10 percent is recommended for flexible brick streets and roads, since larger slopes will cause washout of the jointing sand and braking vehicles will increase the creep of the pavement. Surface grades of up to 15 percent, or even 20 percent, can be used on pavement areas subject to slow moving traffic or pedestrians. However, joint sand stabilization, as well as a high

level of installation quality, is desirable to reduce creep that occurs.

Drainage

Drainage is one of the most important design requirements, since improper drainage may cause failure of the pavement, erosion of the base or subbase, possible deterioration of the pavers, or slippery pavements. Drainage needs to be considered at three levels in the pavement. These are at the surface, to the setting materials and to the pavement structure and subgrade. Surface drainage is undertaken in accordance with standard design concepts for pavement areas. The pavement surface should be finished 1/8 to 1/4 in. (3 to 6 mm) above drainage gratings to allow for potential secondary compaction of the setting bed under trafficking. Surface profiles are covered in the previous paragraph. The bond pattern may affect the flow rate of water over the surface of the paving, as water tends to flow along the joint lines. Surface runoff will increase with time as the joints become filled with debris, however, some water will penetrate the brick surface layer.

Water that penetrates the wearing surface should be drained away from the setting bed and base when the underlying layers are not free-draining. This is particularly the case when the setting bed is placed over a

portland cement concrete slab or a cement or asphalt treated base. Weep holes placed vertically through the portland cement concrete slab may be necessary depending on the environmental conditions. Drainage is less of a concern with bituminous setting beds as some water will percolate through them. It may be necessary to provide a sub-surface drainage system. Sub-surface drainage weeps should be provided at low points and at the edge restraints to drain water to the pavement edge or storm drains. A perforated pipe wrapped with an appropriate geotextile material may be used. The geotextile is necessary to keep small particles from washing out

of the setting bed into sub-surface drains. A drainage layer of open graded aggregate may also be used, but requires proper planning, designing and specifications. Design and detailing of such systems are not included in this Guide, and the reader is directed to the references for several manuals on this subject.

Bond Patterns

Many different bond patterns exist, providing different aesthetic effects, a few of which are shown in Figure 8. Herringbone provides the best resistance to the horizontal forces from accelerating, braking and turning of wheels, and should be used in areas

subjected to heavy vehicular traffic. This is required for sand setting beds and recommended for bituminous setting beds. The pattern can be oriented at 45 degrees or 90 degrees to the direction of traffic. It is not necessary to turn the pattern at corners and bends, as the horizontal interlock is good in all directions.

Many of the pavements laid in the 19th and 20th Century were laid in running bond, either directly across the streets, or occasionally at up to 45 degrees across them. Running bond patterns have continuous joints in one direction. They do not transfer loads well along the continuous joints, and

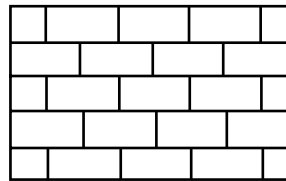

Running Bond

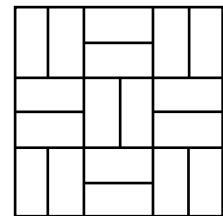

Basketweave

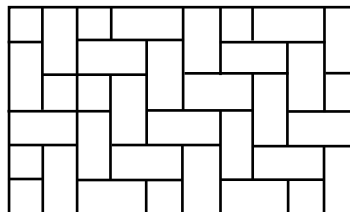

Herringbone

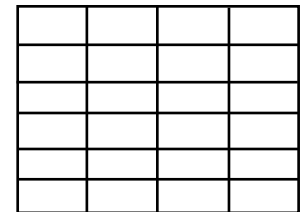

Stack Bond

Figure 8: Bond Patterns

so careful consideration is necessary with their use. **They require smaller joints between pavers in order to minimize creep. Running bond pattern is not recommended for high volume roads and streets. For low traffic volume paved areas the traffic should run perpendicular to the direction of the continuous joints.**

Other bond patterns, such as basketweave and stack bond, can be used in pedestrian areas. This also applies to derivations of these patterns, such as Spanish bond. In all of these arrangements, the patterns include continuous joints in two perpendicular directions. For most basket weave patterns laid in a flexible pavement the bonding ratio of the paver is 2:1 or 3:1 (length: width) for proper alignment of the pattern. Herringbone bond, running bond and stack bond do not have to follow this rule, although joints will not align with a herringbone bond using an irregular module, which may affect installation quality. Basketweave and stack bond patterns tend to show irregularities of the pavers and misalignment of the bond pattern more than other bond patterns. Great care needs to be exercised with such patterns if there is any likelihood of in-place wheel turning.

Some pedestrian plazas and other facilities have been installed using the brick pavers in modules that

coincide with the building grids, tree pits, or other features. Other designs have been created in herringbone bond or bands using different color pavers. When setting out a pattern using fixed dimension modules or different colors, it is important to remember that the individual bricks are not exact sizes. In a modular pattern a consistent 1/16 in. (2 mm) under or over sizing of the bricks, allowable in standard manufacturing tolerances, will soon lead to a shortfall or overrun of several inches in a grid module. This should only be overcome by cutting the bricks to fit, as spacing the pavers with wider joints can affect the structural integrity of the pavement. When mixing different colors of pavers in a pattern area, it is necessary to have an understanding of the potential for different sizes so that the desired appearance is achieved.

Edge Restraints

Edge restraints are necessary along the perimeter of the pavement to prevent lateral movement of the pavers and loss of the setting bed. The edge restraints should be able to resist anticipated loads with minimal movement in order to maintain interlock. Edge restraints can be placed before laying the setting bed, and those incorporating concrete should be cured before

compaction of the brick pavement begins. All edge restraints should be placed to a depth of at least the bottom of the setting bed. Edge restraints are required for both sand set and bituminous setting methods, although the former requires more robust construction. It is important that the inside face of the edge restraint is vertical so that the pavers can be laid against it without a tapered joint that will reduce the integrity.

Concrete Dividers and Inlays

In many pavement areas, the brick pavers are laid between concrete elements that divide the pavement into sections. These are typically 8 to 16 in. (200 to 400 mm) wide. The perception is frequently that this will provide the opportunity to change the pattern orientation or that by incorporating such fixed features it will be possible to prevent creep of the brick pavers. In actuality, it introduces a discontinuity into the pavement that creates a weakness within the traffic area. Placement of small cut pieces, opening of the joints, and settlement of the pavers often occurs at these locations. Therefore concrete dividers are not recommended. Changes in the pattern orientation can be formed by incorporating a header or sailor course of bricks if a band type feature is

required, by a single saw-cut joint line, or by a carefully introduced series of staggered sawcut joints to maintain continuity.

Inlays are also frequently used where a panel of brick pavers is incorporated as an entrance feature. Such inlays are usually surrounded by concrete dividers, or portland cement concrete pavement. When detailing such an inlay it is important that the sides of the dividers are vertical so that interlock can be generated between the bricks and the concrete. The brick pavers should be finished approximately 1/8 in. (3 mm) high against the concrete so that there is accommodation for secondary settlement of the setting bed under traffic. It is also advisable to keep the cut pieces of brick against the edge divider as large as possible, with no pieces less than a quarter of a paver. Thin slivers are particularly vulnerable to damage at these positions. Some benefit can be gained by incorporating a header, sailor, or string course adjacent to the concrete edge.

Traffic Buttons, Reflectors and Paint Markings

Traffic buttons are frequently used as lane markings in streets and roads where snow clearance is

not an issue. These buttons and reflectors are generally secured on the pavement surface with an epoxy adhesive. Setting onto individual brick pavers can be detrimental to the pavement. The impact from vehicle tires can loosen and even dislodge the bricks. It is recommended that alternative means of lane markings are adopted for brick pavers, or that larger, low-profile buttons are used that fix to more than one paver. One effective solution has been to inlay concrete pavers that have a specialized top surface finish. As concrete pavers are typically 3-1/8 (80 mm) thick, they protrude above the pavement surface sufficiently to create tire feedback to indicate their presence.

There are several different types of traffic marking methods for the pavement surface. These include adhesive strips, paints, and thermo-plastics. When in service, the individual brick pavers continue to move independently of each other to a slight degree. As such, the joints open and close a small amount when a wheel passes over them. This movement is often sufficient to cause cracking of the adhesive strip and thermo-plastic markings. Although thinner paint markings frequently have a shorter service life on other pavement materials, they may be more cost effective on brick paved surfaces. Where the visibility of traf-

fic markings is not a legislated requirement, inlaying contrasting colored pavers can provide the most durable option.

Movement Joints

Pavement materials expand and contract as a result of temperature and moisture changes. Flexible pavement materials, such as aggregate, asphalt concrete and cement treated base materials, distribute this movement over the entire pavement areas such that localized strains are very small. As a result the pavers are unaffected by the underlying movement. Brick pavers behave similarly, with any movement taken up in the joints between pavers without putting stress on the brick or edging. Expansion joints are therefore not typically required in such flexible brick pavements. However, when a portland cement concrete slab, used under the flexible brick paving wearing surface, expands and contracts, the movement is concentrated at the joints between the slabs. This movement will be reflected into the overlying pavers, which can be detrimental to the pavement. When the concrete contracts, it causes the overlying joints to open. This results in a loss of interlock, settling of the pavers and a loss of integrity. When the concrete expands it causes the joints to close. This can impose

large horizontal pressure into the brick paver layer, possibly causing paver movement that may result in chipping and spalling of the pavers, and in extreme conditions heaving of the surface. It is therefore necessary to continue expansion joints through the brick and setting bed layer by incorporating edge restraints on either side of the joint. This should be applied to both sand set and bituminous set pavers.

Portland cement concrete slabs are also provided with contraction joints to control cracking during curing. Movement at these locations is less than at expansion joints, and it is not normally necessary to reflect the joints into the surfacing if the underlying contraction joints are at less than 10 ft (3 m) centers. In order to distribute the movement over a wider area it is beneficial to cover the control joints with a strip of geotextiles under the sand bedding course. This is not done under bituminous setting materials.

Design Examples

Example 1

Project Location: Phoenix, AZ

Project type: A residential sub-division local collector street. Used by private automobiles, service vehicles and heavy delivery trucks.

Soil conditions: Low plasticity clay CL

Pavement options: Consider 2-5/8 in. (67 mm) brick pavers on a 1 in. (25 mm) sand setting bed, with an aggregate base course on aggregate subbase and an asphalt treated base on aggregate subbase.

From Figure 7 the project is located in Region V (dry with freeze/thaw cycling). Local data indicates that frost depth is insignificant.

From Table 5 the Pavement Class is PC-5 (Commercial and Residential Local) with traffic expectations of 330,000 ESALs over 20 years.

From Table 3 the soil conditions are fair for average conditions and good for dry conditions.

From Table 8 and the design requirements, the pavement thickness will be 2-5/8 in. brick pavers on 1 in. sand setting bed, laid on 4 in. graded crushed aggregate base over 4-1/2 in. graded aggregate subbase. The total pavement thickness would be 12-1/8 in. (Considering the subgrade similarly drained would only save 1/2 in. of graded aggregate subbase, and so is ignored for the clay subgrade)

From Table 10, the pavement thickness would be 2-5/8 in. brick pavers on 1 in. sand setting bed, laid on 3 in. asphalt treated base over 4 in. graded aggregate subbase. The total pavement thickness would be 10-5/8 in. (Considering the subgrade similarly drained would save the full depth of graded aggregate subbase, but is ignored owing to the clay subgrade)

Example 2

Project Location: Boston MA

Project type: A downtown thoroughfare where traffic studies indicate that the traffic over the design life will be 8×10^6 ESALs

Soil conditions: Clayey sand with an average CBR value of 11.

Pavement options: Consider bituminous set bricks on a cement treated base course (7-day compressive strength 800 psi) on an aggregate subbase and a portland cement concrete slab on an aggregate subbase.

From Figure 7, the project is located in Region II (wet with freeze/thaw cycling). Frost depth is around 22 in.

From Table 5, the Pavement Class is PC-1 (Arterial or Major Street), with traffic expectations of 9,000,000 ESALs over 20 years.

From Tables 2 and 3, the soil conditions are good for average conditions and poor for frost conditions.

From Table 7, the layer coefficient for the CTB is 0.22

From Table 9, the pavement thickness will be 2-5/8 in. brick pavers on 1 in. sand setting bed, laid on 6 in. 650 psi CTB over 9 in. graded aggregate subbase. To consider 3/4 in. bituminous setting bed, add 1 in. to the 6 in. of CTB. To consider 800 psi CTB, multiply 7 in. by 0.2/0.22 = 6-3/8 in. The total pavement thickness would be 18-3/4 in. Add 4 in. to aggregate to exceed frost penetration depth. (Considering poor subgrade conditions to accommodate loss of support requires additional 15.5 in from Table 9)

From Table 11, the pavement thickness would be 2-5/8 in. brick pavers on 1 in. sand setting bed, laid on 9-1/2 in. portland cement concrete slabs over 4 in. graded aggregate subbase. No increase in pavement thickness is required to use a 3/4 in. asphaltic setting bed. The total pavement thickness would be 16-7/8 in. Add 6 in. aggregate subbase owing to frost penetration. (With poor subgrade, the loss of strength would increase concrete thickness by 1 in., rather than adding 6 in. of aggregate subbase)

Part II: Materials

Introduction

The performance of any pavement is only as good as the base, subbase and soil on which it is laid. Quality materials for every layer in the pavement system are vitally important to good performance. Materials should conform to state or local department of transportation (DOT) specifications, ASTM standards, or other applicable industry standards. Project specifications typically require submission of qualifying tests set by the standards.

Base and Subbase Materials

Some pavement systems contain only a base, while others contain a base and a subbase. See Figure 1 for location of layers. The quality or type of base and subbase materials is usually dictated by the design requirements. The design tables are based on various CBR values for the aggregate layers, and compressive strength or Marshall stability for the cement and asphalt treated layers.

Base materials may consist of unbound granular materials, such as crushed aggregate; cement-treated or

asphalt-treated aggregates; or concrete and asphalt bases. Subbases are usually composed of aggregate materials. Aggregate base and subbase materials, including cement- and lime-stabilized materials, are commonly specified in local state and municipal standards for highway construction. All materials should conform to state or local DOT specifications. Materials conforming to ASTM or other industry standards can be used as alternates. The choice and quality of base and subbase materials influences the performance of the pavement. Typically, each layer material can resist progressively higher stresses from the subgrade upward to the wearing course.

Aggregates

The National Stone Association has provided gradation limits for base and subbase aggregate materials, see Table 12. This table is similar to requirements found in ASTM D 2940 Specification for Graded Aggregate Material for Bases or Subbases for Highways or Airports.

Crushed, quarry processed aggregate is preferred because of its ease of construction. The maximum size of aggregate to be used in construction may depend on the size of the project and the size of equipment being used. Proper gradation of materials is required to achieve adequate compaction. Layers consisting of single-size aggregate will not consolidate during compaction and should not be used.

For flexible brick pavements subjected to pedestrian and light vehicular traffic, aggregate graded to "3/4 minus", similar to the gradations in Table 12, is usually sufficient as a base material because it is easy to work with and is readily available. Smaller graded aggregates or rounded

aggregates may not be sufficient to achieve interlock within the aggregate layer and will not transfer loads properly. Open graded (gap graded) aggregates can be used to promote water drainage in areas subjected to frost heave to minimize damage. Geotextiles may be needed to prevent intrusion of smaller material into the open graded aggregates.

Asphalt Bases

New or existing asphalt bases can be used for flexible brick pavements. Specification of asphalt concrete should follow industry standards or local DOT requirements. The adequacy of existing asphalt and the materials beneath should be verified.

Concrete Bases

New and existing concrete bases can be used for flexible brick pavements. New concrete slabs should be specified, with reinforcement as needed, and constructed according to industry practice. Concrete bases should be properly cured before installing the flexible brick paving. High early strength cement may be used to reduce the time

before the wearing surface is placed. Existing concrete slabs should be checked for appropriate strength and repaired or reinforced as necessary. A geotextile can be used where there is a possibility of loss of sand through cracks or holes in the existing slab. The adequacy of the materials beneath the existing concrete slab should be verified.

Soil and Base Stabilization

Subgrade soils or granular material unsuitable for use alone may be treated to produce a stronger layer. The subgrade soil may be stabilized by adding portland cement or lime, depending on the quality of the soil. Subbase and base materials may be improved by adding portland cement, lime, asphalt or pozzolanic materials. Modifying unsuitable materials is considered when economically feasible or where suitable untreated materials are in short supply, although caution should be used in specifying treated soils. Their use should be based on local availability and experience.

Aggregate subbase materials, as well as cement- and lime-stabilized materials, are commonly specified in local state and municipal standards for highway construction.

TABLE 12: Gradation for Base and Subbase (National Stone Association)

Sieve Size	Grading Requirements for Dense Graded Material			
	Design Range ^a		Job Mix Tolerances	
	Percent Passing, by Weight		Percent Passing by Weight	
	Bases	Sub-bases	Bases	Subbases
2 in. (50 mm)	100	100	-2	-3
1-1/2 (37.5)	95 to 100	90 to 100	± 5	± 5
3/4 in (19 mm)	70 to 89	—	± 8	—
3/8 in. (10 mm)	50 to 70	—	± 8	—
No. 4 (4.75)	35 to 55	30 to 60	± 8	± 1-
No. 30 (600 µm)	12 to 25	—	± 5	—
No. 200 (75 µm)	0 to 8 ^b	0 to 12 ^b	± 3	± 5

^a Job mix formula should be selected with due regard to availability of materials in the area of the project. Job mix tolerances may permit acceptance of test results outside the design range.

^b Determine by wet sieving. Where climatic conditions (temperature and availability of free moisture) indicate that in order to prevent damage by frost action a lower percentage passing the No. 200 sieve than permitted above, appropriate lower percentages shall be specified.

Setting Beds

Sand Setting Bed

Sand used as the setting bed should be a washed, well-graded, sand with a maximum size of about 3/16 in. (4.8 mm). Sand conforming to ASTM C 33 Specification for Concrete Aggregates is acceptable. Table 13 shows the gradation limitations taken from ASTM C 33. In addition, the amount of material passing the 75 µm (No. 200) sieve should be limited to no more than 3 percent. The sand particles should be sub-angular. For pavements subjected to heavy channelized traffic, experience has shown that only naturally

occurring, washed silica sand with no silt content should be used. The gradation for the silica sand in channelized traffic should be as shown in Table 14 and no more than 0.3% passing the 75 µm (No. 200) sieve.

An excess of fine particles can increase the moisture sensitivity of the bedding sand. Bedding sands with high fines content can lead to rutting and movement forms of distress. It is not only important to ensure that the fine content is satisfactory on the selected bedding sand, but also that it will not break down under heavy traffic. A degradation test can be undertaken on the bedding sand to compare different bedding sand options. The test involves rotating sand samples with a

charge of ball bearings, on a bottle roller for six hours. The sand particles wear or break down in the process, generating finer particles. The increase in fine particles passing the No. 50, No.100 and No. 200 sieve sizes can be compared with each other to select the best performing sand.

Mason's sand, limestone screenings, or stone dust should not be used as they do not compact uniformly, are normally too soft, and some may cause efflorescence. Soft materials, such as stone screenings, tend to break down over time into smaller particles. Cement should not be added to the sand because it makes removal and reuse of the pavers difficult, adds to the expense of the system, and may cause durability problems.

Bituminous Setting Bed

The bituminous setting bed system can be used as an alternative to a sand setting bed system. The sand bed is replaced by an asphalt coated sand mixture that is bonded to the underlying pavement layer with a tack coat. The brick pavers are in turn bonded on to this bituminous setting bed with a rubberized asphalt adhesive.

The most common material for the tack coat is an SS-1 or SS-1h asphalt emulsion complying with ASTM D 977 Specification for Emulsified Asphalt. Typical application rates are 0.05 to 0.15 gallons per square yard (0.23 to 0.68 liters per square meter) dependent on the surface texture and porosity. Graded crushed aggregate base layers may require up to twice this rate.

The asphalt cement for the bituminous setting bed should be the same grade as that specified for the surface course construction in the appropriate state department of transportation or city highway specification. This may be a viscosity grade conforming to ASTM D 3381 Specification for Viscosity-Graded Asphalt Cement for Use in Pavement Construction (AC-10 or AC-20, and AR-2000 or AR-4000 are the most common) or a performance grade conforming to AASHTO MP 1 Specification for Performance Graded Asphalt Binder (designated as PG grades that are dependent on high and low temperatures in the area). The type of asphalt cement will govern the mixing and rolling temperatures. The fine aggregate for the bituminous setting bed should be a natural or manufactured sand that complies with ASTM D 1073 Specification for fine Aggregate for Asphaltic Paving Mixtures, grading No. 2, or similar material used as fine aggregate at the asphalt plant. All particles should pass the No. 4 sieve. A typical gradation is shown in Table 15.

A local asphalt plant supplies the bituminous setting bed material. Generally only small loads, up to 5 tons (4.5 metric tons), are required at one time so that the work can be completed before the material cools and becomes unworkable. It is manufactured by combining the dried fine aggregate with hot asphalt in the asphalt plant. The approximate proportions are 6-8% of asphalt cement with 94-92% of fine aggregate or approximately 1 gallon of asphalt cement to 110 lbs of fine aggregate (1 liter to 13 kg). The exact proportions should be verified before supplying material for the project. The materials are mixed at a temperature of 300-325° F (149-163° C).

The adhesive is generally a neoprene modified asphalt product specifically developed for setting pavers. It consists of a rubberized asphalt (typically 2% neoprene) with inorganic fibers (typically 10% non-asbestos fibers). However, other products including cold pour rubberized asphalt crack filling compounds have also proven to be successful.

TABLE 13: Gradation for Bedding Sand (ASTM C 33)

Sieve Size	Percent Passing, by Weight
9.5 mm (3/8-in.)	100
4.75 mm (No. 4)	95 to 100
2.36 mm (No. 8)	80 to 100
1.18 mm (No. 16)	50 to 85
600 µm (No. 30)	25 to 60
300 µm (No. 50)	5 to 30
150 µm (No. 100)	0 to 10
75 µm (No. 200)	Less than 3

TABLE 14: Gradation for Bedding Sand in Channelized Traffic

Sieve Size	Percent Passing, by Weight
3/8 in. (9.5 mm)	100
No. 4 (4.75 mm)	95 to 100
No. 8 (2.36 mm)	75 to 100
No. 16 (1.18 mm)	55 to 90
No. 30 (600 µm)	35 to 70
No. 50 (300 µm)	0 to 35
No. 100 (150 µm)	0 to 5
No. 200 (75 µm)	0 to 0.3

TABLE 15: Gradation for Bituminous Setting Bed Aggregate

Sieve Size	Percent Passing, by Weight
No. 4 (4.5 mm)	100
No. 8 (2.36 mm)	75 to 100
No. 16 (1.18 mm)	50 to 74
No. 30 (600 µm)	28 to 52
No. 50 (300 µm)	8 to 30
No. 100 (150 µm)	0 to 12
No. 200 (7 µm)	0 to 5

Jointing Sand

Jointing sand used between the brick pavers should generally have smaller particles than the setting bed material so that it completely fills the joints. The sand particles should be sub-angular. Pavers without lugs and with tighter dimensional tolerances may require finer jointing sand. Appropriate materials must be used to avoid sand wash-out or sand being sucked out by tires. Bedding sand (ASTM C 33) is recommended for joint filling in heavy vehicular pavements. However, the larger particles often will not enter the joints and should be swept off the surface. The remaining sand particles require significant encouragement to fully penetrate the joints. Success has been obtained by passing the bedding sand through a No. 8 sieve. This can be done at the jobsite or by the sand supplier before the material is delivered. Mason's sand may be used for lighter traffic conditions, and should be graded to the limits in ASTM C 144 Aggregates for Masonry Mortar shown in Table 16. The often rounded shape of the finer grade mason's sand makes it susceptible to removal from the joints. Thus, the use of stabilizers should be seriously considered. Other successful sands have been specially graded, dried and bagged for joint filling. They are frequently available from some paver manufacturers. Limestone screenings or stone dust should not be used for the reasons listed under Setting Beds.

For bituminous setting bed systems it is necessary to provide stabilized joint sand as the joint sand is not as well packed into the joints. Without a stabilizer, creep can be excessive and joint sand erosion is likely. Mixtures of portland cement and sand have been used with varying success, but are not recommended. If such a mixture is used it should consist of 1 part of portland cement and 6 parts of sand. The materials are mixed dry before filling the joints, and are brushed over the surface. The surface is fogged so that water penetrates the joints and hydrates the cement. Staining or a resulting rigid system is undesirable results of this practice.

Liquid polymer sealants are proving to be more successful than the sand cement mix. They can also be used for areas subjected to heavy flows of water.

These products are a water repellent, applied to bind jointing sand particles together. It is typically sprayed and squeegeed over the surface so that it soaks into the joint sand and only a thin film remains.

Dry mix stabilizers are mixed with dry jointing sand and swept into the joints. The binding mechanism is activated by applied water. In order to achieve satisfactory penetration and binding of the sand, it is inappropriate to use the ASTM C 144 manufactured sand when liquid polymer sealants are applied. This sand has a high percentage of very fine particles which prevent the penetration of the stabilizer to a satisfactory extent. The stabilizers should bind the sand in the top 1/2 in. (12 mm) of the joint.

TABLE 16: Gradation for Jointing Sand (ASTM C 144)

Sieve Size	Percent Passing, by Weight	
	Natural Sand	Manufactured Sand
4.75 mm (No. 4)	100	100
2.36 mm (No. 8)	95 to 100	95 to 100
1.18 mm (No.16)	70 to 100	70 to 100
600 µm (No. 30)	40 to 75	40 to 75
300 µm (No. 50)	10 to 35	20 to 40
150 µm (No. 100)	2 to 15	10 to 25
75 µm (No. 200)	0 to 5	0 to 10

TABLE 17: Brick Paver Types and Applications

ASTM Specification and Type	Traffic Type	Typical Applications
ASTM C 1272, Type F and R	Heavy vehicular traffic	Roadways, city streets, parking lots, ports
ASTM C 902, Type I	High frequency pedestrian, light vehicles	Driveways, entranceways, parking lots
ASTM C 902, Type II	Intermediate frequency pedestrian	Exterior walkways, pedestrian plazas

Brick Pavers

Brick pavers should conform to ASTM C 902 Specification for Pedestrian and Light Traffic Paving Brick or ASTM C 1272 Specification for Heavy Vehicular Paving Brick. The pavers are classified by the type of traffic they are subjected to during use.

Pavers covered by ASTM C 902 are intended to support pedestrian and light vehicular traffic with low volumes of traffic. The pavers can be used in applications such as residential patios and driveways, sidewalks, plazas, and commercial driveways. Pavers covered by ASTM C 1272 are intended to support high volumes of heavy vehicles. The heavy duty pavers can be used in applications such as roads, streets, and crosswalks. Heavy vehicular traffic is defined as high volumes of heavy vehicles representing trucks or combination vehicles that have 3 or more loaded axles. A possible measure of high volume is over 25 ESALs per day or 200,000 ESALs over the pavement life. Table 17 shows the traffic type and applications for brick pavers.

Minimum Thickness

Brick pavers set in a sand setting bed with sand between the pavers used in a heavy vehicular pavement require a minimum thickness of 2-5/8 in. (67 mm) to achieve interlock. This thickness is exclusive of any chamfers. Thinner pavers will not provide interlock and may move in place, allowing cracking of the pavers. The same thicknesses apply to pavers on bituminous setting beds.

Durability

The durability of brick pavers is predicted by properties such as compressive strength, absorption and saturation coefficient. The saturation coefficient, also referred to as the C/B ratio, is the ratio of 24 hour cold water absorption to the 5 hour boiling water absorp-

tion. ASTM C 1272 requires the brick to meet a minimum compressive strength and a maximum cold water absorption. ASTM C 902 pavers must meet a minimum compressive strength, a maximum cold water absorption, and a maximum saturation coefficient. Table 18 shows the physical property requirements for the different classes of paving brick. Paving brick subjected to freezing temperatures should equal or exceed the physical property requirements for ASTM C 1272, Type R or F, or ASTM C 902, Class SX.

Because raw materials and production methods for brick vary throughout the country, it is difficult to use only the physical property requirements to classify all brick. Therefore, there are alternates which permit the use of those brick which perform satisfactorily in service but do not meet the physical requirements listed in Table 18. Using the alternates in ASTM specifications permits the use of brick that are known to perform well in their intended application. It does not signify that the brick are of a lower quality.

Flexural Strength

It is unlikely that a brick paver will ever fail in compression (crushing) while in service. Instead, the critical property is the flexural strength. A point load, such as a tire, transmits a force to the paver that is supported beneath by a uniform resisting load. The ability of a brick paver to resist a point load is measured by either the modulus of rupture or the breaking load. Each is evaluated according to ASTM C 67 Test Methods of Sampling and Testing Brick and Structural Clay Tile (AASHTO T32.) In these tests an individual paver is supported near its ends and a downward force applied midway between the two supports. ASTM C 1272 establishes a minimum breaking load value shown in Table 18. ASTM C 902 does not have requirements for flexural strength.

Abrasion Resistance

Paving brick are exposed to the abrasive effect of pedestrian and vehicular traffic. Of these two types of traffic, pedestrian traffic can cause the most wear of the pavement surface. Areas attracting concentrations of pedestrian traffic, such as doorways, gates, and even automatic teller machines, deserve special attention. The high volume and impact force of high-heeled shoes cause

TABLE 18: Physical Requirements for Brick Pavers

ASTM Specification and Type	Minimum Compressive Strength, psi (MPa)		Minimum Breaking Load lb./in. (kN/mm)		Maximum Cold Water Absorption, %		Maximum Saturation Coefficient	
	Average of 5	Individual	Avg. of 5	Individual	Avg. of 5	Individual	Avg. of 5	Individual
C 1272, Type R	8,000 (55.2)	7,000 (48.3)	None	None	6	7	None	None
C 1272, Type F	10,000 (69.0)	8800 (60.7)	475 (83)	333 (58)	6	7	None	None
C 902, Class SX	8,000 (55.2)	7,000 (88.3)	None	None	8	8	0.78	0.80
	4,000 (27.6) ^a	3,500 (24.1) ^a			16 ^a	18 ^a		
C 902, Class MX	3,000 (20.7)	2,500 (17.2)	None	None	14	17	None	None

^a Molded Brick

the highest degree of abrasion. Tires on roadways do not have such a drastic effect, unless studded tires are permitted. Brick roads will polish with repeated tire traffic which results in a slightly lower skid resistance value.

The abrasion resistance of brick pavers is determined in one of two ways: 1) an abrasion index is calculated by dividing the cold water absorption by the compressive strength and then multiplying by 100, or 2) by determining the volume abrasion loss in accordance with ASTM C 418 Test Method for Abrasion Resistance of Concrete by Sandblasting. The abrasion requirements for paving brick are listed in Table 19.

The abrasion index is an expedient measure since compressive strength and absorption tests must be calculated for durability purposes. The abrasion index has correlated well with in-field performance.

The volume abrasion loss is determined by submitting a paver to the sandblasting test for a duration of two minutes. The flow rate and grading limits of the sand differ slightly from ASTM C 418. The volume loss is determined by filling the abraded depression with modeling clay, then calculating the volume lost during sandblasting.

Slip and Skid Resistance

The slip resistance of a paving surface is related to pedestrian traffic, while skid resistance is related to vehicular traffic. The slip and skid resistance are measures of the slipperiness of a surface. A surface with a high slip or skid resistance is relatively safe, while a low value may indicate a hazardous surface.

Slip resistance is adversely affected by water on the surface of the pavement. It is the surprise of walking from a slip resistant surface onto a wet or nonslip

resistant surface that causes many falls. Since the slip resistance relies on the microtexture of the paving brick, a brick with a rougher wire cut surface will have a higher slip resistance value.

Skid resistance measures the potential of vehicles skidding on the roadway surface. For the relatively slow speeds expected on flexible brick pavements, the skid resistance depends upon the microtexture of the paver surface. Joints between the pavers and chamfered edges also have a positive effect on the overall skid resistance. A pendulum friction tester is used to measure skid resistance. The pendulum tester, ASTM E 303 Method for Measuring Surface Frictional Properties Using the British Pendulum Tester, measures the wet skid resistance value of unused individual pavers. Typical values for new brick pavers from the British Pendulum Test range from 50 for smooth pavers to over 80 for wirecut sur-

faces. Other tests, such as the fixed trailer, allow the testing of larger sections of pavements that take into account the positive aspect of joints.

Over time, the skid resistance of all paving surfaces decreases because of the polishing effect of the traffic. The skid resistance value for most brick is initially very high and decreases while in use, approaching an equilibrium condition several months after placement. The skid resistance values are also affected by seasonal factors. The British Pendulum Tester can also measure the Polished Paver Value (PPV) after the paver has been in service.

Dimensions

The size and the associated dimensional tolerances of paving brick are more important in flexible brick pavements than in other brick paving applications. Pavers with accurate dimensions are easier for the installer to lay with adequate spacing between

TABLE 19: Abrasion Requirements for Pavers

Paver Specification and Type	Abrasion Index (Max)	Volume Abrasion Loss (Max) (cm ³ /cm ²)
ASTM C 1272, Type R and F	0.11	1.7
ASTM C 902, Type I	0.11	1.7
ASTM C 902, Type II	0.25	2.7

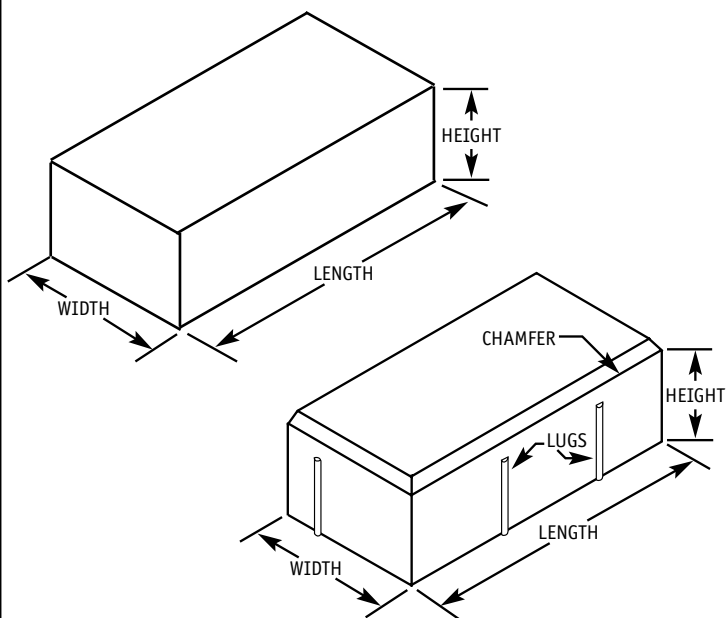

TABLE 20: Common Sizes of Brick Pavers^a

Width, in. (mm)	Height, in. (mm)	Length, in. (mm)
4 (102)	2 1/4 (58)	8 (203)
4 (102)	2 3/4 (70)	8 (203)
4 (102)	3 (76)	8 (203)
3 5/8 (92)	2 1/4 (57)	7 5/8 (194)

^a Check with manufacturer for availability of chamfers and lugs.

TABLE 21: Dimensional Tolerances for Pavers

Paver Specification and Application	Maximum Permissible Variation, in. (mm) ±			
	< 3 in. (76 mm)	Over 3 to 5 in. (76 to 127 mm)	Over 5 to 8 in. (127 to 203 mm)	Over 8 in. (203 mm+)
ASTM C 1272, Application PS	1/8 (3.2)	3/16 (4.8)	1/4 (6.4)	5/16 (7.9)
ASTM C 1272, Application PX	1/16 (1.6)	3/32 (2.4)	1/8 (3.2)	7/32 (5.6)
ASTM C 902, Application PX	1/16 (1.6)	3/32 (2.4)	1/8 (3.2)	7/32 (5.6)

them. These joints, formed by the careful placement of each unit, ensure interlock and reduce chippage of pavers.

Commonly available sizes of pavers for flexible pavements are listed in Table 20. The edges of pavers may be square or may have a small chamfer or rounded edges. When chamfers are present it is recommended that they not exceed 3/16 in (5 mm) in depth or width. The minimum height of the paver necessary for interlock does not include the height of any chamfer. The top edges of pavers with chamfers or rounded edges are less likely to touch during compaction or in service, reducing the potential for chipping.

Specially-shaped pavers are available from some manufacturers lending a decorative effect to the pavement. The shape, other than the ratio of maximum length to thickness, has no measurable effect on the interlock between the pavers or on the strength of the pavement. Pavers should be dimensioned so that the ratio of maximum length to thickness is less than 3 to 1.

Some pavers also are made with lugs or spacers. These lugs, usually 1/8 in. (3 mm), space the pavers apart and provide a uniform gap for jointing sand. The lugs also keep the paver edges from touching during compaction and in

service. This may reduce the amount of chippage on the paver. Lugs are usually necessary when the pavers are subjected to heavy vehicular traffic. When lugs are on only one side or one end of the paver, they are included when measuring the length or width. This approximates the dimensions between the centers of the joints. When lugs are included on both sides and both ends of the paver, the lugs share the space between the pavers. Thus, only one lug is included when measuring the length or width of the paver.

The dimensional tolerances for pavers are shown in Table 21. For flexible pavements subjected to vehicular traffic, ASTM C 1272, Type F or ASTM C 902 Application PX is recommended. Brick with larger dimensional tolerances will be difficult to install, especially with herringbone and basketweave patterns, and may not provide interlock.

Other Materials

Surface Coatings

Colorless coatings (i.e. water repellents) are generally not recommended on exterior brick pavements. The wrong type of coating may not permit vapor transmission (evaporation) and may trap water within a paver. This may lead to

damage due to freeze/thaw or spalling of the face due to build up of crystalline deposits of soluble salts or ice beneath the coating. Non-penetrating type coatings will wear off quickly in high traffic areas.

However, coatings that prevent erosion of the jointing sand may be beneficial. In that case, the coating should be of a type that has a high vapor transmission rate, and will not affect the slip/skid resistance of the paver. The stabilizer should be water based.

Geotextiles

Geotextile fabric materials can be used to separate layers of materials in the paving system. Geotextiles can also be used as a filter material in many drainage applications. Subgrade soil can be prevented from migrating into the base or subbase by use of a geotextile. Other uses of geotextiles range from providing erosion control to being used to reinforce subgrade beneath the pavement by adding strength to the system. Geotextile manufacturers should be consulted to determine applicability of geotextiles in flexible brick paving applications. The recommended minimum apparent opening size of the geotextile should be No. 70 (0.2 mm). The geotextile fabric may be either woven or nonwoven, and should be placed so that the material extends up the side of the excavat-

ed area a sufficient distance to cover the base material. They should overlap approximately 24 to 36 in. (610 to 914 mm) to maintain strength. Only woven geotextiles should be used directly under the bedding sand, as this location is highly abrasive, and can separate the fibers on non-woven materials.

Edge Restraints

Edge restraints are mandatory in flexible brick pavements. Edge restraints hold the pavers together and provide for interlock of the wearing surface. Many different types of edge restraint materials exist, including brick, rigid plastic, wood, steel, aluminum, or concrete. The type of application determines which material to use. Any of the materials listed can be used in pedestrian applications. Only concrete, brick placed in concrete, some varieties of rigid plastic, or steel edgings should be used in areas subjected to vehicular traffic. In heavy vehicular applications, only cast-in-place concrete should be used. Flexible pavement materials, such as brick set in sand, loose aggregates, or asphalt, are not suitable as edge restraints.



Part III: Construction

Introduction

The in-service performance of the pavement depends on the preparation and installation of the underlying materials. If the materials are not placed and compacted properly, then the entire brick pavement system may not perform as intended. Properly sized joints between pavers, completely filled with jointing sand, are essential to complete interlock and for long term performance.

Subgrade

The subgrade is excavated, if necessary, to achieve the required finished level. Any unsuitable material, such as organic material, large rocks, etc., should be removed from the subgrade and replaced with suitable backfill. The subgrade should be drained and protected against flooding and ground water by sub-soil drainage. The installation of pipes and sub-soil drainage should be completed before initiating the base or subbase construction. The width of the subgrade should be sufficient to extend to the back edge of the proposed edge restraint or abut existing structures.

To achieve the best performance from the subgrade it is necessary to scarify the top surface, condition it to the proper moisture content, and then to recompact it to established relative densities. The moisture content of the soil must be within allowable limits of the optimum moisture content and be carefully monitored to achieve maximum compaction. The subgrade soil should be compacted to at least 95% maximum density if they are granular and to at least 90% maximum density if they are cohesive. The method of compaction and compaction equipment may vary due to soil type and size of area being compacted. Figure 9 is a general guide to the

appropriate choice of compaction equipment. Subgrade preparation is commonly specified in local state and municipal standards for highway construction. It is also likely that the geotechnical report will provide recommendations on minimum compaction standards.

Various tests are used to determine the proper compaction and density of the soil. Laboratory compaction tests to determine proper placement requirements include:

- Standard Proctor Test, ASTM D 698 Methods for Laboratory Compaction Characteristics of Soil Using Standard Effort (12,400 ft-lb/ft³ (600 kN-m/m³)) or AASHTO T9 Test Methods for Moisture-Density Relations of Soils and Soil-Aggregate Mixtures Using 5.5 lb. (2.5 kg) Rammer and 12 in. (305 mm) Drop; and
- Modified Proctor Test, ASTM D 1557 Test Method for Laboratory Compaction Characteristics of Soil Using Modified Effort (56,00 ft-lb/ft³(2,700 kN-m/m³)) or AASHTO T180 Test Methods for Moisture-Density Relations

of Soils and Soil-Aggregate Mixtures Using 10 lb. (4.5 kg) Rammer and 18 in. (457 mm) Drop.

The latter of these tests is normally used to test materials that support heavier loads for higher shear strength.

Field tests which determine soil density provide a method to check for conformance to job specifications. Three field tests are often used:

- Sand Cone Test, ASTM D 1556 (AASHTO T191) Test Method for Density and Unit Weight of Soil in Place by the Sand Cone Method.
- Water Balloon Test, ASTM D 2167 (AASHTO T205) Test Method for Density and Unit Weight of Soil in Place by the Rubber Balloon Method; and
- ASTM D 2922 (AASHTO T238) Test Methods for Density of Soil and Soil-Aggregate in Place by Nuclear Methods (Shallow Depth).

It is important to remember that the maximum density varies between samples, and so proper soil identification

is required to establish the appropriate target density for each location.

Because brick paving is frequently used as hard landscaping adjacent to major building projects, it is often the case that designers are not familiar with highway testing and construction procedures. Therefore, great care must be taken in evaluating and testing the subgrade. For best results then, follow the procedures outlined in this Guide along with the advice of a pavement design professional.

Subbase

This Guide considers various types of subbase material as set out in Table 7 and the associated text. These include graded aggregate, cement- and lime- stabilized soils. Basic assumptions on the types of materials are in the table. Subbase courses should be designed following Part I of this Guide, or guidelines and specifications of local authorities.

Geotextile fabric may be used to separate the subgrade soil from an aggregate subbase, especially in soils subject to moisture levels near or at saturation. The geotextile will prevent intrusion of the subgrade soil into the bottom of the aggregate subbase or vice versa. They must be placed without wrinkles and lapped at their edges.

The aggregate subbase course materials should be spread and compacted in layers. In-place mixing and compaction of the stabilized materials can be carried out, or mixing can be undertaken remotely and the mixture spread and compacted in layers. The thickness of these layers must be consistent with the capabilities of the compaction equipment. All subbase materials should be compacted to a minimum of at least 95 percent of maximum density. The subbase should also extend at least one layer thickness past the edge of the overlying layer to enable adequate compaction at the edges of the pavement. Typically, the thickness of each layer is approximately 3 to 4 in. (76 to 102 mm), but can increase to double these thicknesses if appropriately heavy compaction equipment is used.

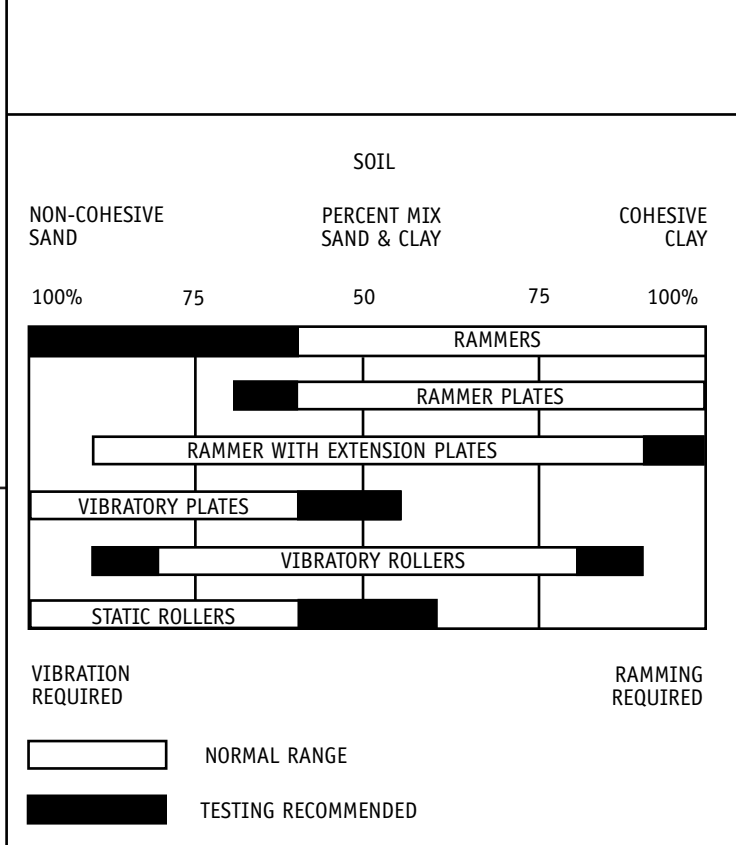

Figure 9: Soil Compaction Guide

Compaction should be completed as soon as possible after the material has been mixed and spread. The profiles should be such that water is channeled towards drainage facilities.

Base

The design tables in this Guide provide options for various types of base course material. These include graded aggregate bases, cement-treated bases, and asphalt-treated bases. Thickness of portland cement concrete slabs on an aggregate subbase is also considered. Details can be found in Table 7 and the associated text. Base courses should be designed following Part I of this Guide, or guidelines and specifications of local authorities.

Geotextile fabric may be used to separate the subgrade soil from the compacted base, especially in soils subject to moisture levels near or at saturation. The geotextile will prevent intrusion of the subgrade soil into the bottom of the aggregate base or vice versa. They must be placed without wrinkles and lapped at their edges.

The base course materials should be spread and compacted in layers. The thickness of these layers must be consistent with the capabilities of the compaction equipment. See Figures 10, 11 and 12. All base materials should be compacted to a minimum of 95 percent maximum density. The base should also extend at least 6 in. (150 mm) past the edge restraint if spikes are used to hold the restraint in place.



Figure 10: Leveling Base



Figure 11: Proper Base Compaction

Typically, the thickness of each layer is approximately 3 to 4 in. (76 to 102 mm). The surface of the base should be close-knit to prevent setting bed material from filtering downwards through the base. It must be of good quality to avoid failure due to high stress concentrations immediately under the wearing surface.

Compaction should be completed as soon as possible after the material has been spread. It is essential that the intended surface profile of the base be formed so that the pavers can be placed on a uniform thickness of bedding sand.

Sand Setting Bed

The sand setting bed material is spread over the base in a uniform thickness. The setting bed is not meant to, and should not, be used to fill in low spots or bring the pavement to the correct grade. The thickness of the setting bed should be 1 in. (25 mm) thick with a tolerance of plus or minus $\frac{3}{16}$ in. (5 mm). Setting bed thicknesses that are excessive could lead to shifting of the setting bed material, causing loss of strength.

The sand is typically spread over the base between 1 in. (25 mm) diameter screed rails. These are set to a pro-

file to provide sufficient depth in the uncompacted bedding layer, to account for the reduction from compaction. Screed rails are typically placed 8 to 12 ft. (2.4 to 3.7 m) apart, and at closer centers when a changing grade is required. There are several specialized screeding systems that enable more rapid installation and result in less foot traffic on the sand. On some large projects, asphalt paving machines have been used to spread the sand.

The setting bed sand should not be spread too far in front of the laying face of the pavers to prevent disturbance. The sand should be screeded without compaction to a level slightly higher than the final thickness of the layer. The sand should be disturbed as little as possible since the final pavement surface will reflect any variation. The voids left by the screed rails should be filled from the paver laying face as work progresses. The common practice of filling from the screeding side can leave localized areas of over compacted sand, which results in subsequent high spots. If the sand is disturbed, the area should be rescreeded. Prepared areas should not be left overnight, unless they are properly protected from disturbance and moisture. The moisture content of the setting bed sand should be as uniform as possible, and the material should be moist without



Figure 12: Compacting Near Edge

being saturated. Water should not be added to screeded sand except as a very light misting. Stockpiled material should be kept covered.

The screeded bedding sand is vulnerable to environmental disturbance from wind or rain. Care needs to be taken so that water cannot drain back into the bedding sand when it is uncovered or covered with pavers but not vibrated.

Bituminous Setting Bed

The first step in constructing this system is to apply a tack coat over the base layer to achieve a level of bonding

and moisture protection. The tack coat will generally be supplied to the site in drums or pails due to the limited area at any application time. The air and substrate temperature should be above 50°F (10°C). The material should be at a temperature of about 80°F (27°C) or above when applied. A continuous, uniform coat should be applied by spraying, squeegeeing or brushing the material. Typical application rates are 0.05 to 0.15 gallons per square yard (0.19 to 0.57 liters per square meter), depending on surface texture and porosity. Work should not be carried out in rainy conditions. The tack coat must cure for 1/2 to 1 hour (until it turns black and is

dry to the touch) before applying the bituminous setting bed.

A local asphalt plant supplies the bituminous setting bed material. Generally only small loads, up to 5 tons (4.5 Mg), are required at one time so that the work can be completed before the material cools and becomes unworkable. The materials are mixed at a temperature of 300 to 325°F (149 to 163°C). The mixed material should be delivered to the site in an appropriate covered truck. The truck bed should be steel that is clean and a lubricant should be used to help with discharge.

Steel screed rails, typically 12 ft. (3.7 m) long, are set

up on timber packs to achieve a uniform profile. These are typically at 10 to 12 ft (3 to 3.7 m) centers, oriented along the profile of the street. When establishing the profile, it is important to allow for the likely compaction of the setting bed. The hot material is spread over the surface of the tack coat and screeded off to a nominal thickness of $\frac{3}{4}$ in. (19 mm). Care should be taken to ensure that release agents applied to the screed rails and tools do not cause damage to the bituminous setting bed. The screeded panels are advanced down the street as each screed rail length is completed. To minimize foot traffic on the screeded material, alternate panels are constructed so that the screed rails and timber packs can be removed and the infill panel screeded using the edges of the two outside panels. The infilling of narrow slots where screed rails have been removed should be minimized, as this can result in a variable density and differential compaction. Screeding should be undertaken while the material is still hot. Particles of colder material will drag under the screed rule and result in a rough surface. As the layer is thin it will cool quickly. Once the asphalt sand mixture has cooled to a suitable temperature it is rolled to provide a smooth, uniform surface. A walk-behind or small ride-on steel drum roller, with a weight of 200 to 300 lbs per ft (300 to 450 kg per m) width of drum, should be used. On small projects and in confined locations, a vibratory plate compactor may be used.

There are two different degrees of compacting the bituminous setting bed. In one, the bituminous setting bed is laid and lightly compacted with the roller. This results in a setting bed with an open texture and high void content. In the second system, the bituminous setting bed is more thoroughly compacted during the rolling process. This results in a more closed surface with less texture.

Paver Installation

General

Work may start from an exact edge or from the centerline of the pavement. The pavers should be laid in the desired bond pattern, with a joint width between $\frac{1}{16}$ in. (2 mm) and $\frac{3}{16}$ in. (5 mm) on all sides. Pavers with square edges or without lugs, should not be forced together or laid "hand tight", as this can result in excessively tight joints, which may cause the pavers to chip during installation, compaction or service. Pavers with lugs provide the correct gap when they are placed in contact with each other.

String lines or chalk lines may be used to keep the pattern straight. It may be necessary to slightly alter the pattern module to accommodate the exact dimension of the pavers. Straight and true bond lines are necessary in areas subjected to heavy vehicular traffic to provide a uniform distribution of horizontal loads. The spacing of the string lines should be based on the contractor's experience, size of the project and speed of laying. It is inadvisable to open joints above $\frac{3}{16}$ in. (5 mm) to avoid cutting at an edge. The wider joints are likely to lead to greater creep and a reduction in structural integrity.

Whole pavers should be laid first, followed by cut pavers. After the area is laid with whole pavers, it is easy to fill in the spaces

with pavers cut to size. All pavers should be cut with a masonry saw to produce an accurate, clean cut. The blade should have a soft bond matrix and a high diamond concentration in order to cut clay pavers effectively. A trial area may be laid out in advance of work to determine paver positions to minimize the amount of cutting and maintain cut pieces of sufficient size. A rule of thumb is to have the minimum face dimension of the cut piece not less than the paver thickness. It is common practice to run one or two rows of pavers laid in stack bond (sailor course) along edge restraints. This facilitates subsequent cutting of pavers and ensures that the cut is between similar materials.

A herringbone pattern laid at 45° or 90° to the edge

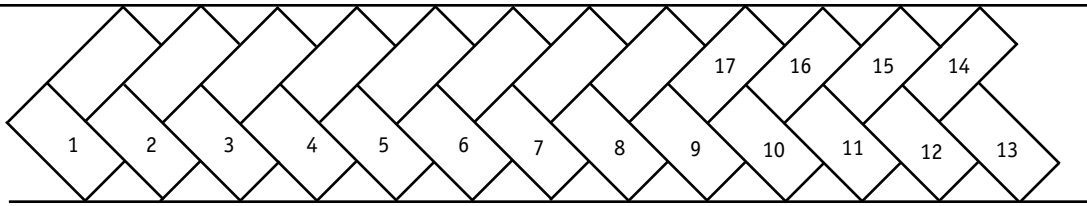

Figure 13: 45° Herringbone Installation Pattern

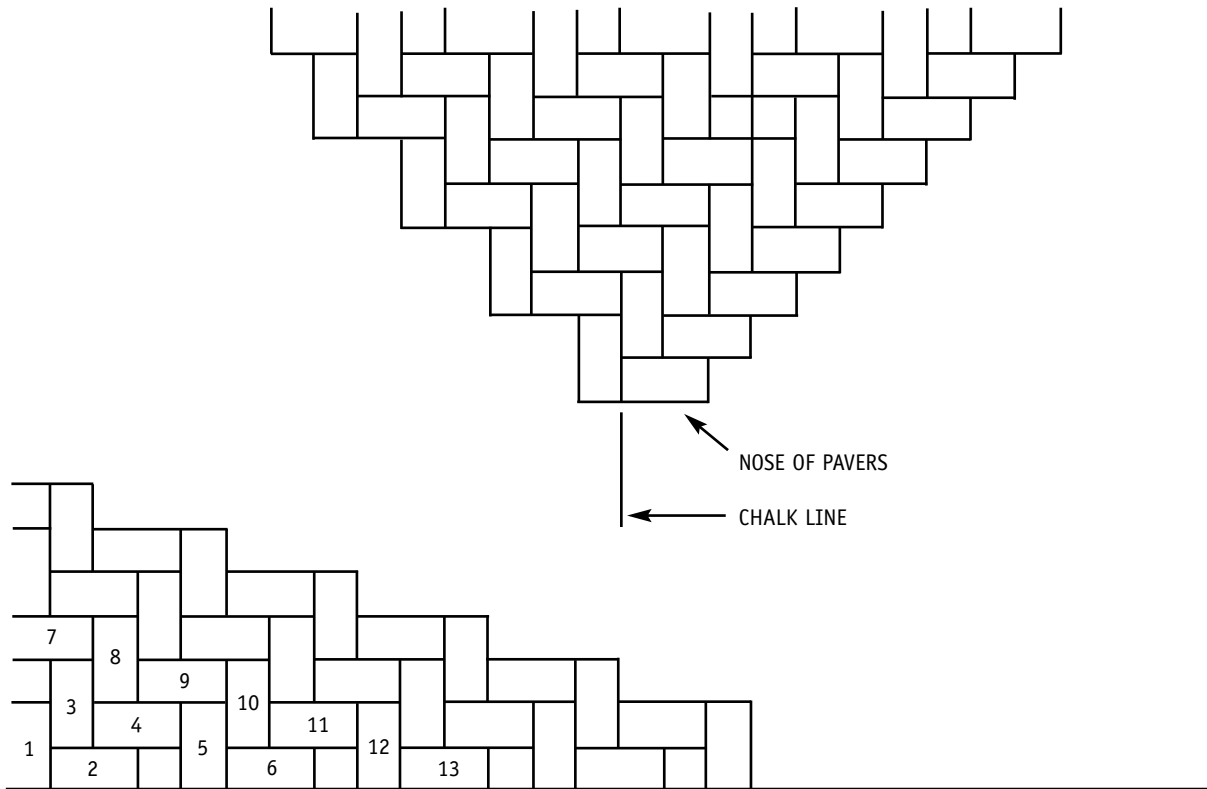

Figure 14: 90° Herringbone Installation Pattern

of the pavement should be used for vehicular applications. A 45° herringbone may be started along an edge and continue parallel to that edge. See Figure 13. A 90° herringbone should be started, if possible, at an exact corner or the centerline of the area to be paved. Otherwise, a “pyramid” of pavers should be advanced over the area along a line, as in Figure 14. If a running bond pattern is used, the pavers should be laid so that their long dimension is

perpendicular to the flow of traffic. In all cases, the bond pattern should be checked periodically to ensure proper alignment. Slight adjustments can be made in the thickness of the joint, since it is far easier to replace a row or two of pavers than to reconstruct an entire area.

Pavers on Sand Setting Bed

The installer works off of the pavers already in place.

Felt or other geotextiles should not be placed directly beneath the brick pavers. Felt does not allow interlock, since the setting bed is not allowed to integrate with the jointing sand between the pavers during compaction. After the pavers have been placed on the sand setting bed, the brick pavement is vibrated by a mechanical plate vibrator/compactor. The first pass is done without jointing sand spread on the surface, as shown in Figure 15. Prior to subse-

quent passes of the compactor, jointing sand is spread across the surface before compaction, as shown in Figure 16. The jointing sand should be dry and spread on the pavement until the joints appear full. If movement of the pavers occurs as a result of wide joints adopted when the bricks do not have spacers, a light distribution of bedding sand over the surface before vibration can be beneficial. If chipping of the pavers occurs, laying geotextiles



Figure 15: Compaction of Brick Pavers, with Protection

material on the surface before vibration can be beneficial. Obviously the initial vibration and placement of the jointing sand should be accomplished as soon after placing the pavers as possible and before any traffic is permitted on the paving.

A plate compactor with a high frequency/low amplitude plate, equipped with a rubber mat or a rubber-roller mechanical vibrator, is used. Use of a steel drum roller is likely to cause some cracking of the bricks. If it is used in vibration mode, significant damage can occur. The plate area should not be less than 2 ft² (0.19 m²) and produce 3,000 to 5,000

lbs. (13.3 to 22.3 kN) of centrifugal force. Compaction should not occur within 6 ft (2 m) of any unrestrained edge.

Pavers on Bituminous Setting Bed

The pavers are set on an adhesive spread on the bituminous setting bed. When the setting bed is lightly compacted, the adhesive drains down into the surface texture of the setting bed. With the light compaction the pavers are typically loose at first so they can be aligned. When the pavement surface carries traffic, the pavers com-

press the lightly compacted setting bed and squeeze the adhesive back to the interface between the setting bed and the pavers. This achieves a good bond and full coverage of the bottom of the paver. It is good practice to roll the surface of the completed paving with a heavy rubber tire roller. This will enhance the compaction of the bituminous setting bed if the pavement is to be used by heavy vehicles, reducing the likelihood that rutting will develop in the wheel paths.

When the setting bed is highly compacted, the adhesive does not penetrate into the setting bed

and the quantity of adhesive can be better controlled. Troweling is typically used to spread it. The pavers are then set close to their final position, as they become difficult to move when the adhesive hardens.

The adhesive can be cold applied, but should be above 70 °F (21 °C) for best results. It is applied at a coverage rate of 30 to 50 sq ft per gal (0.84 to 1.2 sq m per liter), by brush, squeegee or trowel, depending on its viscosity. The adhesive should be spread at least two hours before setting the pavers.

The brick pavers are placed by hand onto the adhesive. The installer works off of the pavers already installed. They are placed with joint widths of 0 to 1/16 in. (1.6 mm) to the correct laying pattern, and aligned as soon as possible to form straight lines. Wider joints should be discouraged and the pavers should be placed as close together as possible while maintaining the alignment. When the pavers have lugs, they may be placed in contact with each other for best results and to minimize creep.

Traffic should not be permitted on the paving until the joints are filled with jointing sand that is stabilized. The preferred method is to use dry sand and a stabilizer. Dry joint sand is brushed into the



Figure 16: Sweeping Joint Sand

joints in the same manner as for sand set systems. No vibration is used. When the joints are full, the sand is swept off so that it is level with the bottom of the chamfers or the top of the pavers. If a dry stabilizer is used, it is mixed with the dry sand prior to application. The dry stabilizer is activated with applied water to bind the sand particles. A liquid joint sand stabilizer that binds the sand particles together, if used, is

applied after the dry sand is brushed into the joints and the excess swept off. It is sprayed and squeegeed over the surface so that it soaks into the joint sand and only a thin film remains on the surface of the pavers. It is important that the stabilizer is water based as solvents can harm the adhesive and setting bed materials. It is possible to wet the surface of the pavers or allow time for the sand

to settle to encourage complete filling of the joints. However, the moisture should be allowed to dissipate prior to applying liquid stabilizer.

An alternative, and not recommended process, is mixing cement with dry joint sand and brushing it into the joints. No vibration is used. When the joints are completely filled, the surface of the pavers is lightly misted so that the water penetrates the joints

and hydrates the cement. It is possible that some settlement of the joint filling material will occur so that a second treatment may be required. Care must be taken to ensure that no cement is left on the pavement surface as stains may result. This is particularly difficult if the pavers have a rough surface texture or are engraved.

Tolerances

The final surface elevation should be left slightly above adjacent pavement to allow for secondary compaction of the bedding layer under traffic. It is typical for an additional $1/8$ in. (3 mm) of compaction to occur, but local experience should govern. The maximum variation in level should be within $\pm 3/16$ in. in 10 ft (± 5 mm in 3 m). Pavers adjacent to drainage inlets and channels should be left slightly higher, but not more than $3/16$ in. (5 mm) above it. The edges of any two adjacent pavers should not differ more than $1/8$ in. (3 mm) if the pavers have chamfers, or $1/16$ in. (1.6 mm) if they have square edges. Paver to paver tolerances are measured either chamfer to chamfer or top edge to top edge. The bond line to which the paver pattern is laid also has dimensional tolerances. These should be within $\pm 1/2$ in. in 50 ft (± 10 mm in 15 m).

In Service Considerations

Surface Coatings

Colorless coatings, i.e. water repellents, are generally not recommended on exterior brick pavements. See the discussion in Part II: Materials. If surface coatings are to be applied, the manufacturer's instructions for application should be followed.

Repairs

At some time during the life of a flexible brick pavement, repairs or utility work beneath the pavement may require the removal and replacement of pavers from the working area. When starting repairs, a single brick should be removed, preferably with a purpose-made tool. It may be necessary to break a few pavers to start the removal. Adjacent pavers are then removed and stacked nearby to be used again if not damaged. The pavers should be cleaned of adhering sand by brushing. Cleaning of asphaltic material is usually difficult, and it may be necessary to remove pavers set on bituminous setting beds from the site for cleaning with a solvent. Temporary edge restraints should be placed at the perimeter of the removal area.

Excavation of trenches should follow established procedures. Proper compaction of the returned fill material is very important. If the area is too small for proper compaction, stabilized materials, such as concrete, should be used. The compacted fill should be brought up to the proper level. One or two feet (0.3 to 0.7 m) of pavers around the perimeter of the excavated area should be removed so that accurate levels can be established from undisturbed work. At all times, vehicular traffic should be kept at least 6 ft (2 m) away from the work edges.

Setting bed material should be screeded to the proper grade. The setting bed should be compacted and a thin layer of sand screeded on top. Temporary edge restraints are removed and the pavers are then laid in the correct bond pattern. Some creep of the pavement may have occurred during repairs; therefore, some pavers may have to be saw cut to fit. Jointing sand should be spread over the top of the pavers and the system vibrated to the finished level with a plate compactor. Two or three passes may be necessary to fill the joints. Dependent upon the type of backfill used in the excavation, it may be appro-

priate to set the pavers high of the final surface so as to accommodate any consolidation. Providing a slight arch to the profile will help in maintaining a good fit.

Maintenance

Although brick paving surfaces are very durable, some routine maintenance may be necessary.

Efflorescence

Efflorescence, a white powdery substance produced by soluble salts, may be unavoidable on a paving surface. Deicers used on adjacent areas may be deposited onto the brick pavement, soluble salts may be present within paving system components, or salts may migrate from adjacent soils. Therefore, proper drainage and maintenance are especially critical to reduce the amount of efflorescence. If efflorescence does appear on the paving surface, natural weathering or traffic will usually eliminate it. Efflorescence should not be removed from the surface with acids. There are proprietary efflorescence removers available.

Snow Removal

Snow removal from brick pavements should not present any particular problem. It can be removed by plowing, blowing or brushing away the snow. When using plows or shovels there are precautionary measures that can be taken to preserve the surface character of the brick. Metal blades should be rubber or urethane tipped or mounted on small rollers. The blade edge should be adjusted to a clearance height suitable for the pavement surface. When hand shoveling, shovel at an angle to the paver edge to avoid catching it. Avoid the use of any chemicals containing rock salt (calcium chloride) to aid in melting ice. Use of these materials may cause efflorescence. Calcium magnesium acetate is recommended for snow and ice removal. Urea is used to melt ice at many airports without causing efflorescence, but it is not effective below 20 °F (-7 °C). Otherwise, remove snow before it can be compacted or turn to ice. To render icy surfaces passable, use clean sand or ashes on the icy areas.



Closing

Brick has been used as a paving material for centuries, however, the design and construction of an interlocking flexible brick pavement for heavy vehicular applications is a fairly new concept. This Guide provides designers with information on how to design, construct and specify a properly performing flexible brick pavement. The materials and construction procedures recommended in this Guide are similar to those used for other pavements.

The information and recommendations in this Guide must be used in conjunction with good engineering judgment and a basic understanding of the properties of brick and related construction materials. Information on local materials and local experience should be applied when available.

References

1. American Association of State Highway and Transportation Officials, *Guide for Design of Pavement Structures*, Washington, D.C., 1993.
2. Brick Development Association, *BDA Design Note 9, Flexible Paving With Clay Pavers*, United Kingdom, Oct. 1988.
3. Brick Industry Association, *Flexible Brick Pavements: Heavy Vehicular Pavements, Design and Installation Guide*, Reston, Virginia, 1991.
4. Clay Brick and Paver Institute, *Paver Note One, Specifying and Laying Clay Pavers*, Australia, Aug. 1989.
5. Clifford, J.M., *Segmental Block Paving in Southern Africa - A Review and Structural Design Guide*, National Institute for Transport and Road Research, Republic of South Africa, Sept. 1986.
6. Knapton, J. and Barber, S.D., *UK Research into Concrete Block Pavement Design*, 1st Concrete Block Paving Conference, Newcastle-upon-Tyne, United Kingdom, 1982.
7. Knapton, J. and Mavin, K.C., *Design Manual 1, Clay Segmental Pavements*, Clay Brick and Paver Institute, Australia, Jan. 1989.
8. National Stone Association, *Flexible Pavement Design Guide for Roads and Streets*, Jan. 1985.
9. Pavement Consultancy Services, *Structural Design of Roads and Streets using Concrete Block Pavements*, National Concrete Masonry Association, Herndon, VA, Jan. 1989.
10. *The Total Concept*, Blockleys, plc, United Kingdom, 1988.
11. *Understanding Soil Compaction*, J.I. Case Co., Racine, WI, 1988.
12. Walsh, I.P., *A Comparative Field Study of the Performance of Brick Pavers*, Chemistry and Industry, Nov. 1985.

Appendix A

Definitions of Terms

AASHTO (American Association of State Highway and Transportation Officials): National association of highway officials.

Base: The layer or layers of specified materials of designed thickness placed on a subbase or a subgrade to support the wearing surface.

CBR (California Bearing Ratio): A measure of the shear strength or stability of a soil or granular material, expressed as a percentage of the strength of a standard material and measured by a constant rate of strain penetration machine either in-situ or in a laboratory.

Cement Lime-Stabilization: A technique that improves the strength or stability of clay soils (subgrades) by the incorporation of portland cement or lime.

Compaction: The process that consolidates the subgrade, subbase or base; the process by which the brick pavers are settled into the setting bed during construction and jointing sand is vibrated into the joints between the pavers to create interlock.

Creep: Horizontal movement of the brick pavers generally caused by the braking actions of vehicular traffic.

Edge Restraint: Resistance to horizontal movement at the edge of the pavement provided by sufficiently rigid supports.

ESAL (Equivalent Single Axle Load): The representation of the passage of an axle of any mass (load) by a number of 18-kip (80 kN) equivalent single axle loads.

Frost Heave: Localized volume changes that occur in the roadbed soil as moisture collects and freezes into ice lenses.

Geotextile Fabric: Any permeable textile material used to separate pavement layers.

Heavy Vehicular Traffic: Traffic consisting of high volumes of heavy vehicles. Heavy vehicles are considered trucks.

Herringbone: A bonding pattern with alternate pavers at right angles to each other forming a zigzag effect. Generally recommended in vehicular traffic applications.

Interlock (Lock-up): The effect of frictional forces, induced by sand beneath and between the brick pavers that inhibits movement of the paver and transfers loads between adjacent pavers.

Layer Coefficient: The empirical relationship between structural number (SN) and layer thickness that expresses the relative ability of a material to function as a structural component of the pavement structure.

Appendix B

Referenced Standards

Light Vehicular Traffic: Traffic consisting of automobiles or lighter vehicles.

Lug (Spacer or Nib): A small projection on paver edges, formed during manufacturing, designed to provide a positive gap for jointing sand and to minimize chippage of the pavers during installation and in service.

R-value: A measure of strength of a soil material.

Resilient Modulus (MR): The modulus of elasticity of roadbed soil or other pavement material.

Saturation Coefficient: The ratio of the weight of water absorbed by a masonry unit during immersion in cold water to the weight absorbed during immersion in boiling water. An indicator of the probable resistance of brick to freezing and thawing.

Serviceability: The ability of a pavement to serve traffic that uses the facility at the time of observation.

Setting Bed (Bedding Course): The layer of specified materials in which the brick pavers are bedded, taken together with the pavers to form the wearing surface.

Skid Resistance: A measure of friction between the pavement and a tire assessing the risk of vehicles skidding on the pavement surface.

Structural Number (SN): An index number derived from the analysis of traffic, roadbed soil conditions, and environment which may be converted to thickness of flexible pavement layers through the use of suitable layer coefficients related to the type of material being used in each layer of the pavement system.

Subbase: The layer or layers of specified materials of designed thickness placed on a subgrade to support a base.

Subgrade: The top surface of existing soil or prepared soil upon which the pavement system is constructed.

Wearing Surface: The layer of brick pavers and setting bed, which serves as the paving surface, and modeled as a single layer.

AASHTO MPI	Specification for Performance Graded Asphalt Binder
ASTM C 33	Specification for Concrete Aggregates
ASTM C 67 (AASHTO T32)	Test Methods of Sampling and Testing Brick and Structural Clay Tile
ASTM C 144	Specification for Aggregates for Masonry Mortar
ASTM C 418	Test Method for Abrasion Resistance of Concrete by Sandblasting
ASTM C 902	Specification for Pedestrian and Light Traffic Paving Brick
ASTM C 1272	Specification for Heavy Vehicular Paving Brick
ASTM D 698 (AASHTO T99)	Test Methods for Laboratory Compaction Characteristics of Soil Using Standard Effort (12,400 ft-lb/ft ³ (600 kN-m/m ³))
ASTM D 977	Specification for Emulsified Asphalt
ASTM D 1073	Specification for Fine Aggregate for Asphaltic Paving Mixtures
ASTM D 1556 (AASHTO T191)	Test Method for Density and Unit Weight of Soil in Place by the Sand Cone Method
ASTM D 1557 (AASHTO T180)	Test Method for Laboratory Compaction Characteristics of Soil Using Modified Effort (56,000 ft-lb/ft ³ (2,700 kN-m/m ³))
ASTM D 1883 (AASHTO T193)	Test Method for CBR of Laboratory Compacted Soils
ASTM D 2167 (AASHTO T205)	Test Method for Density and Unit Weight of Soil in Place by the Rubber Balloon Method
ASTM D 2844 (AASHTO T190)	Test Method for Resistance R-Value and Expansion Pressure of Compacted Soils
ASTM D 2487 (AASHTO M145)	Standard Classification of Soils for Engineering Purposes (Unified Soil Classification System)
ASTM D 2922 (AASHTO T238)	Test Method for Density of Soil and Soil-Aggregate in Place by Nuclear Methods (Shallow Depths)
ASTM D 2940	Specification for Graded Aggregate Material for Bases or Subbases for Highways or Airports
ASTM D 3381	Specification for Viscosity-Graded Asphalt Cement for Use in Pavement Construction
ASTM E 303	Method for Measuring Surface Frictional Properties Using the British Pendulum Tester

Appendix C

Guide Specification

Section 02780 Flexible Brick Pavers

PART 1 - GENERAL

1.01 SECTION INCLUDES

- A. Brick Pavers
- B. Sand Setting Bed

or

- B. Bituminous Setting Bed

1.02 RELATED SECTIONS

- A. Section 02710 - Bound Base Courses
- B. Section 02340 - Soil Stabilization
- C. Section 02720 - Base Courses
- D. Section 02750 - Portland Cement Concrete Paving
- E. Section 02770 - Curbs

1.03 QUALITY ASSURANCE

- A. Brick Pavers: Test in accordance with ASTM C 67.
- B. Mock-up
 - 1. Mock-up shall be 10 ft. by 10 ft.
 - 2. When required, provide a separate mock-up for each type of brick and bonding pattern.
 - 3. Do not start work until Architect/Engineer/Landscape Architect has approved mock-up.
 - 4. Use mock-up as standard of comparison for all work.
- C. Installer: Company with at least three years experience in installing brick pavers.

1.04 SUBMITTALS

- A. Submit samples of brick pavers to be used in construction, showing range of colors, textures, finishes and dimensions.
- B. Submit sieve analysis for grading of bedding and jointing sand.
- C. Test reports for masonry units from a qualified testing laboratory.

1.05 DELIVERY, STORAGE AND HANDLING

- A. Store brick pavers off the ground to prevent contamination, staining or other defects.
- B. Cover sand with waterproof covering to prevent exposure to weather. Weigh down covering to prevent removal by wind.
- C. Store different types of aggregates separately.

1.06 ALLOWANCES

- A. Refer to Section 01210 - Cash Allowances for the Cash Allowance Sum applicable to this section.
- B. This allowance includes purchase and delivery of brick pavers. Specially-shaped brick pavers shall have a separate allowance.

1.07 PROJECT CONDITIONS

- A. Do not install sand or pavers during rain or snowfall.
- B. Do not install frozen materials.

1.08 REFERENCES

- A. ASTM C 33 - Concrete Aggregates
- B. ASTM C 67 - Method of Sampling and Testing Brick and Structural Clay Tile
- C. ASTM C 144 - Aggregate for Masonry Mortar
- D. ASTM C 1272 - Heavy Vehicular Paving Brick

PART 2 - PRODUCTS

2.01 BRICK UNITS

- A. Paving Brick: ASTM C 1272, Type F, Application PX [PS] [PA], _____ as manufactured by _____.
Size _____ x _____ x _____.

2.02 SAND

- A. Bedding Sand: ASTM C 33
*** BEDDING SAND CAN BE
USED AS JOINTING SAND. ***
- B. Jointing Sand: ASTM C 144

PART 3 - EXECUTION

3.01 EXAMINATION

- A. Examine base for correct grade and elevations.
- B. Examine edge restraints for proper location.

3.02 INSTALLATION OF FLEXIBLE PAVING

- A. Spread bedding sand evenly over base and screed to 1 in. thickness \pm $\frac{3}{16}$ in. The screeded sand should not be disturbed.
- B. Lay pavers in the pattern(s) as indicated in the drawings. Maintain straight lines.
- C. Joints between the pavers shall be approximately $\frac{1}{16}$ to $\frac{1}{8}$ in. wide.
- D. Fill out area with cut pavers along edges or interruptions.
- E. Vibrate the brick pavers into the sand using a plate vibrator capable of 3000 to 5000 lbs. centrifugal force. The plate vibrator shall have a rubber mat or roller feet to avoid chipping the pavers.
*** LUGS, CHAMFERS OR ROUNDED EDGED
PAVERS REDUCE CHIPPING ALONG THE
TOP EDGES OF THE PAVER. ***
- F. After the first pass of the plate vibrator, sweep jointing sand into the joints and vibrate again. Repeat the process until the joints are full.
- G. Do not permit traffic on the pavers until the joints are filled.
- H. Do not vibrate within six feet of unrestrained edges.
- I. Sweep excess sand off of pavement.

3.03 TOLERANCES

- A. The final surface elevation shall be flush with adjacent construction.
- B. Maximum variation in level shall be within \pm $\frac{3}{16}$ in. in 10 ft.

NOTES





Brick Industry Association
1850 Centennial Park Drive
Reston, VA 20191

(703) 620-0010 phone
(703) 620-3928 fax

brickinfo@bia.org
www.gobrick.com

